

PROPRIETARY RIGHTS ARE CLAIMED FOR THE MATERIAL DISCLOSED IN THIS DRAWING.

LTR.	REVISIONS	DATE
✖	*****	00-00-98

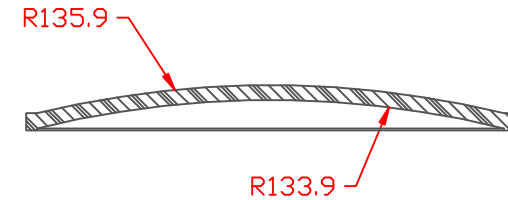
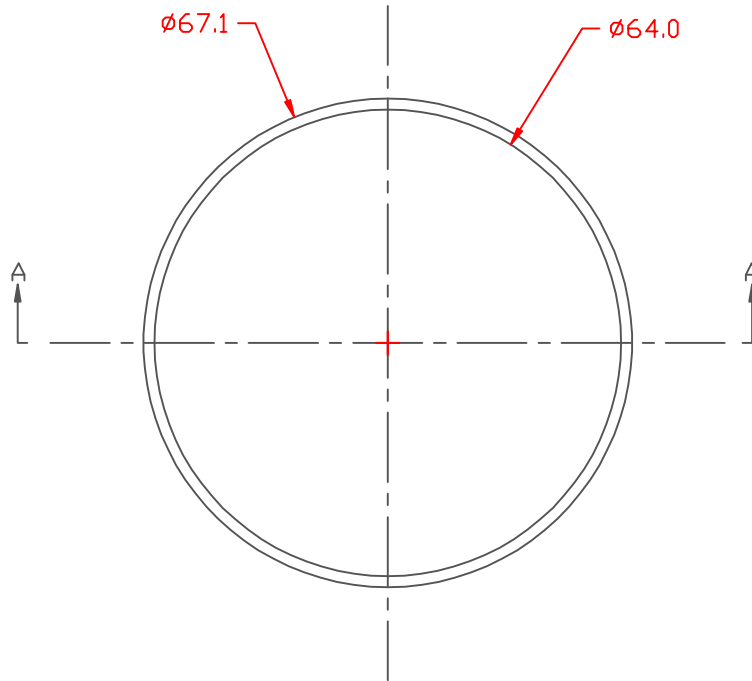

TO BE USED WITH VTE
476 & 480 SERIES

TOLERANCE UNLESS OTHERWISE SPECIFIED: ±.030"/±0.8mm
RADIAL DIAMETERS TO BE MEASURED OVER MANDRELS,
RING GAGES OR PIN GAGES OF SUITABLE SIZE

Material:	Polypropylene
Material Part No:	Polypropylene Copolymer
Max. Operating Temp:	550 F
Durometer:	110 R-Scale
Specific Gravity:	1.13
Ult. Elongation %:	2.5
Modulus PSI:	*****
Tensile Strength PSI:	9500
Dielectric Strength, v./ml:	*****
MEETS:	UL94HB

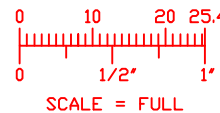

		VTE Incorporated 5437 Robinson Road, P.O. Box 790 Pellston, Michigan 49769 Telephone: 1-800-527-9256, 231-539-8000 FAX: 231-539-0914	
		REF:	DATE: 4-2-98
TITLE: 8D BATTERY TERMINAL BOOT, CAP			
MATERIAL:		PART NO. 479N9P14	
COLOR:	DRG CLASS		