

THE INFORMATION CONTAINED IN THIS DRAWING IS THE SOLE PROPERTY OF VTE INCORPORATED. ANY REPRODUCTION IN PART OR WHOLE WITHOUT THE WRITTEN PERMISSION OF VTE INCORPORATED IS PROHIBITED.

VTE MAKES NO WARRANTY, EXPRESSED OR IMPLIED, AS TO THE SUITABILITY OF A PRODUCT FOR ANY INTENDED USE. THE CUSTOMER SHALL BEAR THE SOLE RESPONSIBILITY OF DETERMINING THE SUITABILITY OF ANY VTE PRODUCT FOR ITS END USE.

LTR.	REVISIONS	DATE
A	ADDED #3652 AND #3653	24JAN03
B	3850-000 WAS 3850, 3850-001 ADDED 2 PLCS.	02MAR07
C	ADDED CALLOUT FOR SPACER AND INSTRUCTION SHEET	01MAY07
D	ADDED CALLOUT FOR P/N 379 PANEL SEAL	13FEB08
E	REVISED TORQUE RECOMMENDATIONS	08JUN10

USE GREENLEE  
PUNCH ASSEMBLY  
#60098 FOR PANEL  
CUTOUT

ASSEMBLY #7B5052W

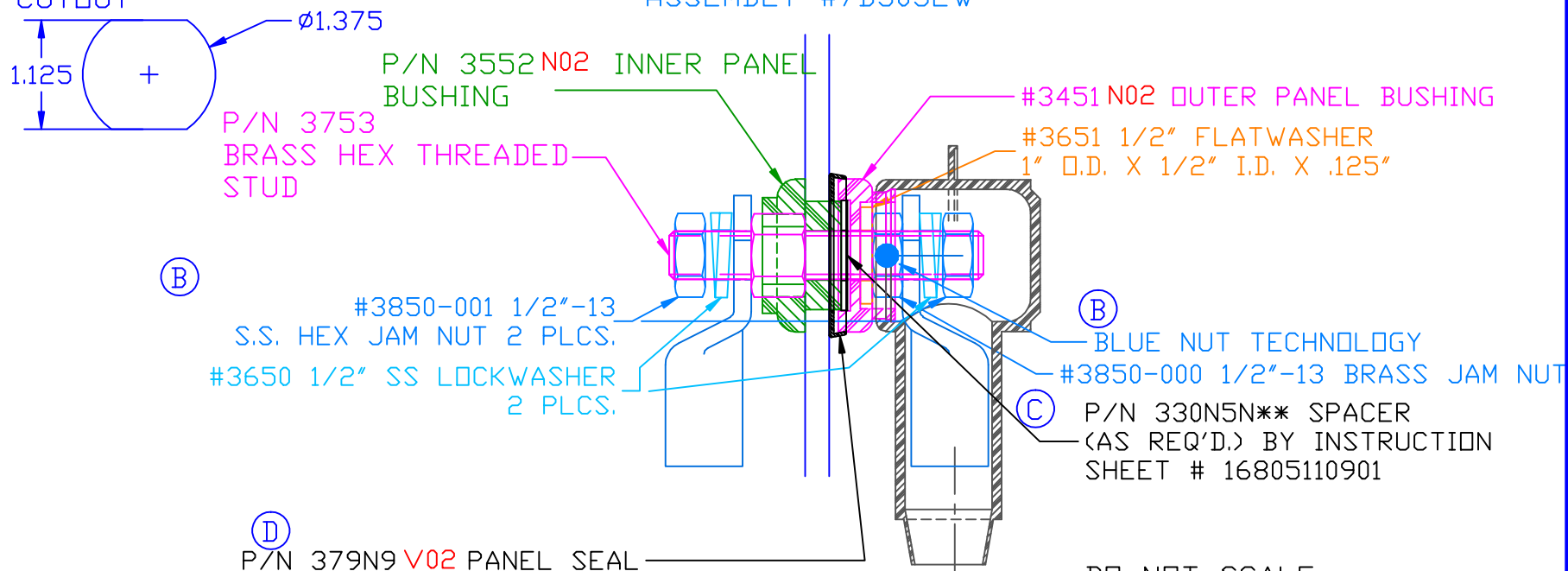

DO NOT SCALE

TOLERANCE UNLESS OTHERWISE SPECIFIED: ±.030"/±0.8mm  
RADIAL DIAMETERS TO BE MEASURED OVER MANDRELS,  
RING GAGES OR PIN GAGES OF SUITABLE SIZE

MAXIMUM AMPERAGE: 500 AMPS @ 12VDC

MAXIMUM RECOMMENDED FASTENER TORQUE:  
BRASS JAM NUT: 240 IN./LBS.  
S.S. JAM NUT: 180 IN./LBS.

INCLUDES: 232E4V02 WEATHERPROOFING TERMINAL COVER

BASE MATERIAL:  
BASE MATERIAL U.L. RATING:

GLASS-REINFORCED NYLON  
94 HB

OPTIONAL ITEMS SHOWN FOR ILLUSTRATIVE  
PURPOSE, NOT INCLUDED:

4/0 GA. TERMINAL LUGS (2 PLACES)

 VTE Incorporated  
5437 Robinson Road, P.O. Box 790  
Pellston, Michigan 49769  
Telephone: 1-800-527-9256, 231-539-8000  
FAX: 231-539-0914

REF: *****	DATE: 02JAN03	DRN BY: BRH	WEIGHT: *****
TITLE: POWER BUSHING 1/2" STUD 3/8" MAX PANEL WEATHERPROOF		CHK'D BY: BRH	SCALE:
MATERIAL:		PART NO.	
COLOR: RED	DRG CLASS: *****	7B5052N02 W	