

THE INFORMATION CONTAINED IN THIS DRAWING IS THE SOLE PROPERTY OF VTE INCORPORATED. ANY REPRODUCTION IN PART OR WHOLE WITHOUT THE WRITTEN PERMISSION OF VTE INCORPORATED IS PROHIBITED. VTE MAKES NO WARRANTY, EXPRESSED OR IMPLIED, AS TO THE SUITABILITY OF A PRODUCT FOR ANY INTENDED USE. THE CUSTOMER SHALL BEAR THE SOLE RESPONSIBILITY OF DETERMINING THE SUITABILITY OF ANY VTE PRODUCT FOR ITS END USE.

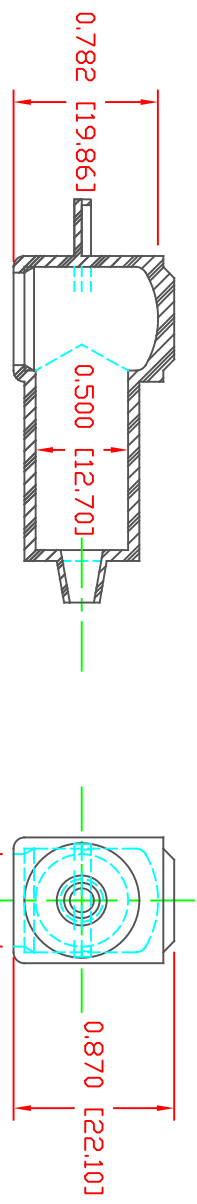

SECTION A-A
 TYP. WALL THICKNESS = .060" [1.5]
 SEAL NO. 1 SHOWN

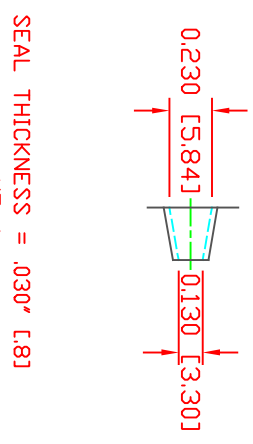
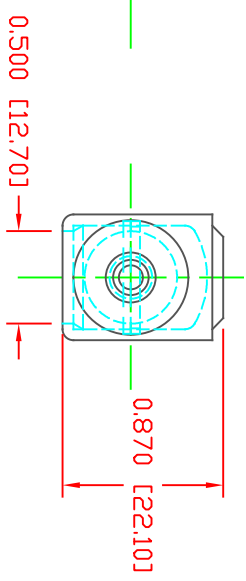

SEAL THICKNESS = .030" [.8]
 NO. 1
 Wire Gauges
 18 - 10

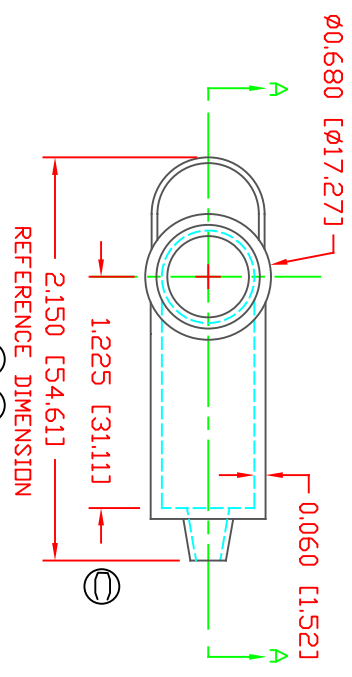

MATERIAL PART NO: 1101700109
 MATERIAL: BLUE PVC
 VENDOR PART NO: 7844-70 BLUE 1812
 SPECIFIC GRAVITY: 1.36
 HARDNESS 10 SEC: 70
 HARDNESS SCALE: A
 TENSILE STRENGTH, PSI: 1100
 ELONGATION, %: 310
 TEAR STRENGTH, PPI: 200
 FLAME CLASS UL: HB
 MELT TEMP., DEGREES F [C]: 320-340 [160-171]
 DIELECTRIC STRENGTH, V./MIL: N/A

LR.	REVISIONS	DATE	INT.
A	UPDATED OVERALL DIMENSIONS	08-27-14	JC
B	ADDED REFERENCE DIMENSION	02-22-16	RAS
C	UPDATED LENGTH DIMENSION FROM 1.250 (31.75)	07-22-22	RAS
D	UPDATED OVERALL REFERENCE DIMENSION FROM 2.175 (55.34)	07-22-22	RAS
E	UPDATED BLUE MATERIAL INFORMATION	08-01-22	RAS

SCALE FACTOR : NONE
 ALL DIMENSIONS GIVEN AS: In [mm]
 TOLERANCES UNLESS OTHERWISE SPECIFIED :
 MOLDED PARTS: ±.030" (±0.8mm)
 ALL ANGLES ARE ± 1 DEGREE

VTE Incorporated
 5437 Robinson Road, P.O. Box 790
 Pellston, Michigan 49769
 Telephone: 1-800-527-9256, 231-539-8000
 FAX: 231-539-0914

REF.	DATE:	DRN BY:	JC	WEIGHT:
CUSTOMER DIMS	10-05-93	CHK'D BY:	JC	.014 LBS (6.12 g)
TITLE: TERMINAL INSULATOR CAP				
MATERIAL:	PVC	PART NO:		214E1V09
COLOR:	BLUE	DRG CLASS	REV E	

DD NOT SCALE