

THE INFORMATION CONTAINED IN THIS DRAWING IS THE SOLE PROPERTY OF VTE INCORPORATED. ANY REPRODUCTION IN PART OR WHOLE WITHOUT THE WRITTEN PERMISSION OF VTE INCORPORATED IS PROHIBITED. VTE MAKES NO WARRANTY, EXPRESSED OR IMPLIED, AS TO THE SUITABILITY OF A PRODUCT FOR ANY INTENDED USE. THE CUSTOMER SHALL BEAR THE SOLE RESPONSIBILITY OF DETERMINING THE SUITABILITY OF ANY VTE PRODUCT FOR ITS END USE.

LTR.	REVISIONS	DATE	INT.
△	ADDED REFERENCE DIMENSION	02-25-16	RAS

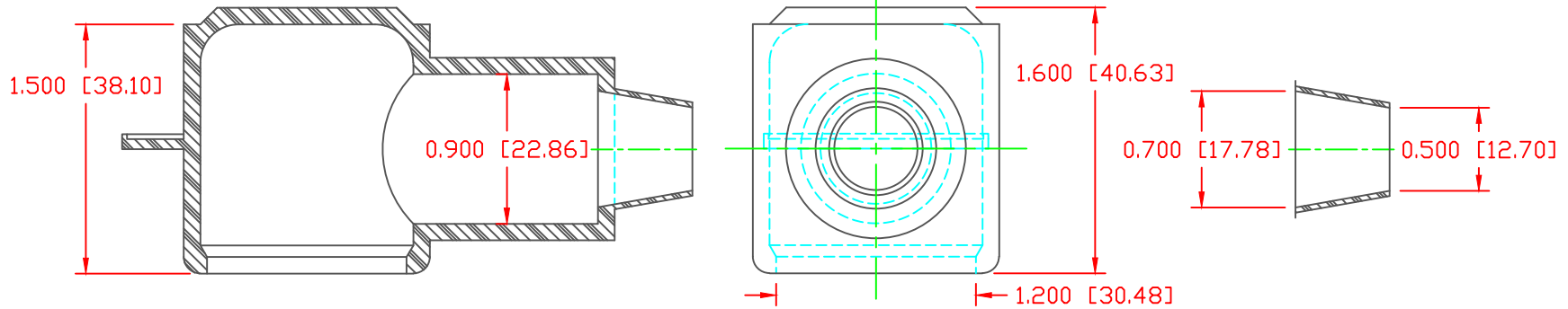

SECTION A-A  
TYP. WALL THICKNESS = .100" [2.5]  
SEAL NO. 3 SHOWN

SEAL THICKNESS = .030" [.8]  
NO. 3  
Cable Gages  
2 - 2/0

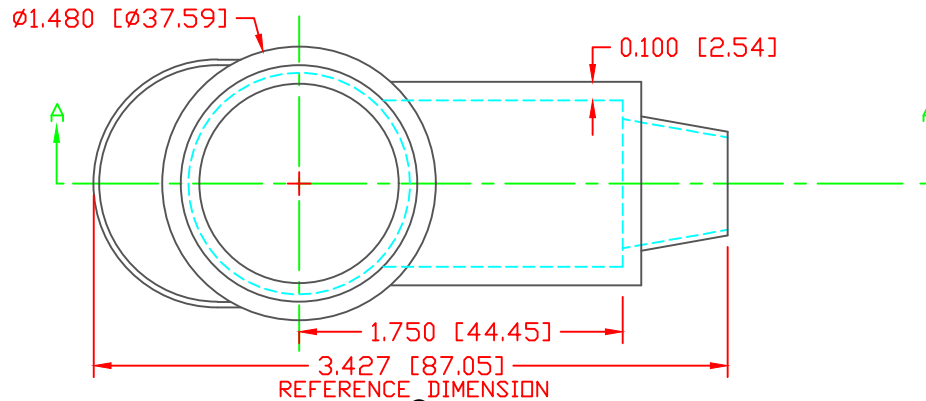

PREFERRED VENDOR:	SYLVIN
PART NO:	1101700109
MATERIAL:	BLUE PVC
VENDOR PART NO:	9067-70 BLUE 1812
SPECIFIC GRAVITY:	1.36
HARDNESS 10 SEC:	70
HARDNESS SCALE:	A
TENSILE STRENGTH, PSI:	1100
ELONGATION, %:	310
TEAR STRENGTH, PPI:	200
FLAME CLASS UL:	HB
MELT TEMP., DEGREES F [C]:	320-340 [160-171]
DIELECTRIC STRENGTH, V./MIL:	N/A

ALL DIMENSIONS GIVEN AS: in [mm]  
MOLDED PARTS: ±.030" [±0.8mm]  
HARDWARE ITEMS: ±.010" [±0.25mm]

		<b>VTE Incorporated</b> 5437 Robinson Road, P.O. Box 790 Pellston, Michigan 49769 Telephone: 1-800-527-9256, 231-539-8000 FAX: 231-539-0914	
		REF: CUSTOMER DIMS	DATE: 03-25-98
TITLE: TERMINAL INSULATOR			
MATERIAL: PVC		PART NO. 232N3V09	
COLOR: BLUE	DRG CLASS: REV A		

DO NOT SCALE