

THE INFORMATION CONTAINED IN THIS DRAWING IS THE SOLE PROPERTY OF VTE INCORPORATED. ANY REPRODUCTION IN PART OR WHOLE WITHOUT THE WRITTEN PERMISSION OF VTE INCORPORATED IS PROHIBITED. VTE MAKES NO WARRANTY, EXPRESSED OR IMPLIED, AS TO THE SUITABILITY OF A PRODUCT FOR ANY INTENDED USE. THE CUSTOMER SHALL BEAR THE SOLE RESPONSIBILITY OF DETERMINING THE SUITABILITY OF ANY VTE PRODUCT FOR ITS END USE.

| LR | REVISIONS | DATE | INT. |
|----|---------------------------|----------|------|
| A | ADDED REFERENCE DIMENSION | 02-25-16 | RAS |
| B | REVISED FROM 0567 | 07-3-24 | RAS |

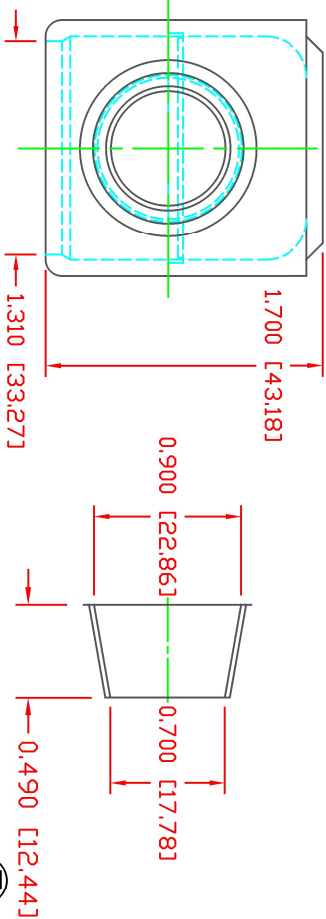
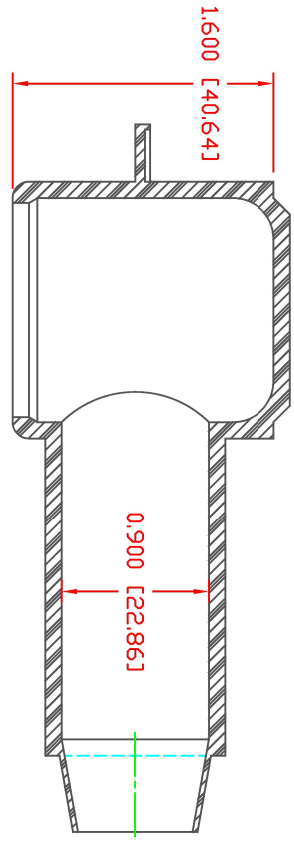

SECTION A-A
 TYP. WALL THICKNESS = .100" [2.54]
 SEAL NO. 4 SHOWN

SEAL THICKNESS = .030" [.8]
 NO. 4
 Cable Gauges
 2/0 - 4/0

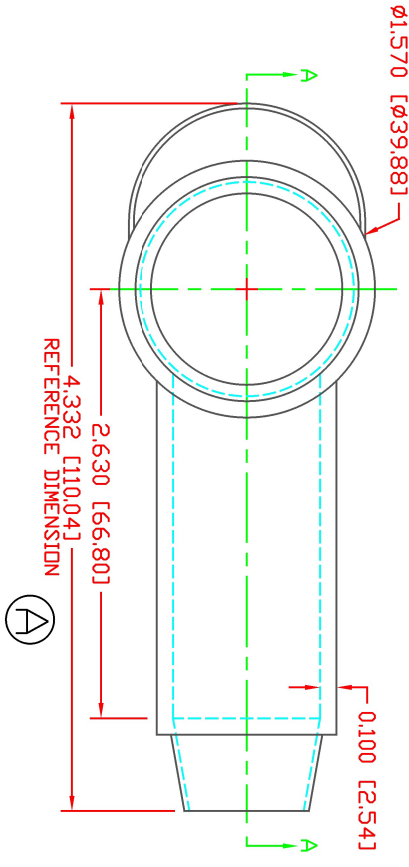

VTE PART NO: 1101700114
 MATERIAL: PVC
 VENDOR PART NO: 7843-70-BLACK
 SHORE DUREMETER: "A" 10 SEC. 70
 SPECIFIC GRAVITY: 1.34
 ULT. ELONGATION %: 350
 MELTING TEMP: 320-340 F [160-171 C]
 BRITTLE TEMP: -22 F [-30 C]
 Tensile Strength PSI: 1500
 Dielectric Strength, v./mil: 500
 U.L. Rating: V0

DO NOT SCALE

ALL DIMENSIONS GIVEN AS: In [mm]
 MOLDED PARTS: ±.030" [±0.8mm]
 HARDWARE ITEMS: ±.010" [±0.25mm]



VTE Incorporated
 5437 Robinson Road, P.O. Box 790
 Pellston, Michigan 49769
 Telephone: 1-800-527-9256, 231-539-8000
 FAX: 231-539-0914

| REFI | DATE | DRN BY | JC | WEIGHT |
|-------------------------------|-----------|----------|----|-------------------|
| CUSTOMER DIMS | 03-25-98 | CHK'D BY | JC | .078 LBS [35.3 g] |
| TITLE: TERMINAL INSULATOR CAP | | | | |
| MATERIAL | PVC | PART NO | | 234E4F14 |
| COLOR: BLACK | DRG CLASS | REV B | | |