

THE INFORMATION CONTAINED IN THIS DRAWING IS THE SOLE PROPERTY OF VTE INCORPORATED. ANY REPRODUCTION IN PART OR WHOLE WITHOUT THE WRITTEN PERMISSION OF VTE INCORPORATED IS PROHIBITED. VTE MAKES NO WARRANTY, EXPRESSED OR IMPLIED, AS TO THE SUITABILITY OF A PRODUCT FOR ANY INTENDED USE. THE CUSTOMER SHALL BEAR THE SOLE RESPONSIBILITY OF DETERMINING THE SUITABILITY OF ANY VTE PRODUCT FOR ITS END USE.

LT#	REVISIONS	DATE	INT.
A	ADDED REFERENCE DIMENSION	02-25-16	RAS
B	REVISED DIMENSION FROM 1.310 [33.27]	03-08-18	RAS
C	UPDATED CABLE GAUGES FROM 2/0 - 4/0	03-28-18	RAS
D	REVISED FROM 0.567 [14.40]	07-3-24	RAS

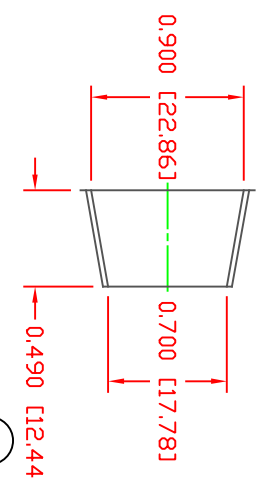
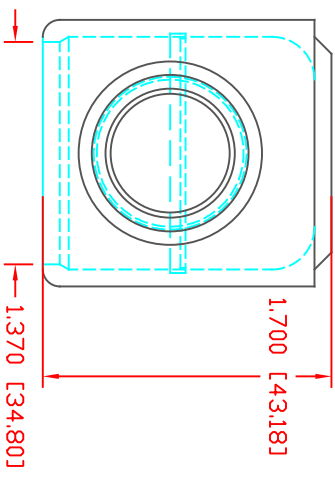
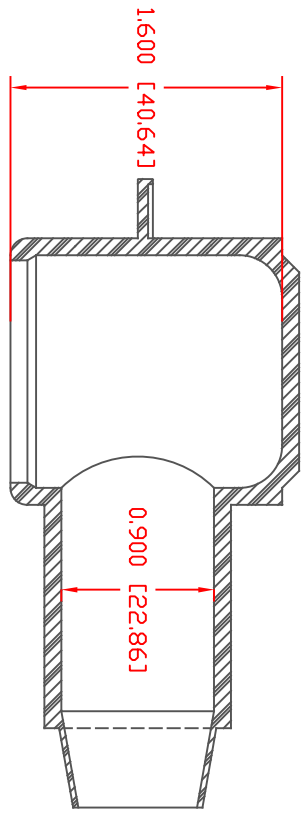

SECTION A-A  
 TYP. WALL THICKNESS = .100" [2.5]

(B)

SEAL THICKNESS = .030" [.8]

(D)

NDL 4  
 Cable Gauges  
 3/0 - 4/0

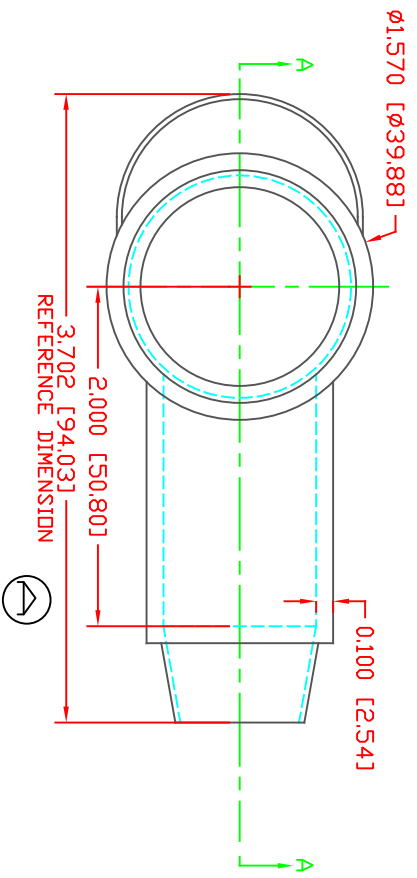

MATERIAL PART NO: 1101700102  
 MATERIAL: PVC  
 VENDOR PART NO: 7843-70-RED 6288  
 SHORE DUREMETER: #A" 10 SEC. 70  
 SPECIFIC GRAVITY: 1.34  
 ULT. ELONGATION %: 350  
 MELTING TEMP: 320-340 F [160-171 C]  
 BRITTLE TEMP: -22 F [-30 C]  
 Tensile Strength PSI: 1550  
 Dielectric Strength, v./mil: 553  
 U.L. Rating: V0

ALL DIMENSIONS GIVEN AS: In [mm]  
 MOLDED PARTS: ±.030" [±0.8mm]  
 HARDWARE ITEMS: ±.010" [±0.25mm]



VTE Incorporated  
 5437 Robinson Road, P.O. Box 790  
 Pellston, Michigan 49769  
 Telephone: 1-800-527-9256, 231-539-8000  
 FAX: 231-539-0914

REF.	DATE:	DRN BY:	JC	WEIGHT:
CUSTOMER DIMS	03-25-98	CHK'D BY:	JC	.067 LBS [30.2 g]
TITLE: TERMINAL INSULATOR CAP				
MATERIAL: PVC		PART NO: 234N4F02		
COLOR: RED	DRG CLASS	REV D		

DO NOT SCALE