

THE INFORMATION CONTAINED IN THIS DRAWING IS THE SOLE PROPERTY OF VTE INCORPORATED. ANY REPRODUCTION IN PART OR WHOLE WITHOUT THE WRITTEN PERMISSION OF VTE INCORPORATED IS PROHIBITED. VTE MAKES NO WARRANTY, EXPRESSED OR IMPLIED, AS TO THE SUITABILITY OF A PRODUCT FOR ANY INTENDED USE. THE CUSTOMER SHALL BEAR THE SOLE RESPONSIBILITY OF DETERMINING THE SUITABILITY OF ANY VTE PRODUCT FOR ITS END USE.

LTR	REVISIONS	DATE	INT.
⊲	ADDED REFERENCE DIMENSION	02-25-16	RAS
⊳	REVISED DIMENSION FROM 1.310 [33.27]	03-08-18	RAS
⊴	UPDATED CABLE GAUGES FROM 2/0 - 4/0	03-28-18	RAS
⊵	REVISED FROM 0.567 [14.40]	07-3-24	RAS

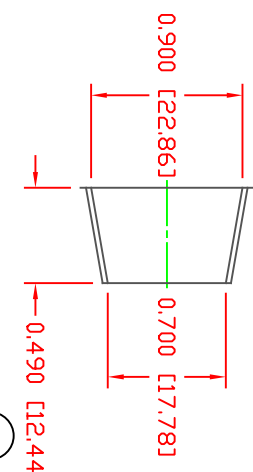

SECTION A-A
TYP. WALL THICKNESS = .100" [2.5]

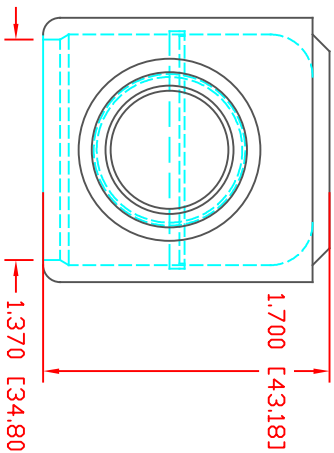
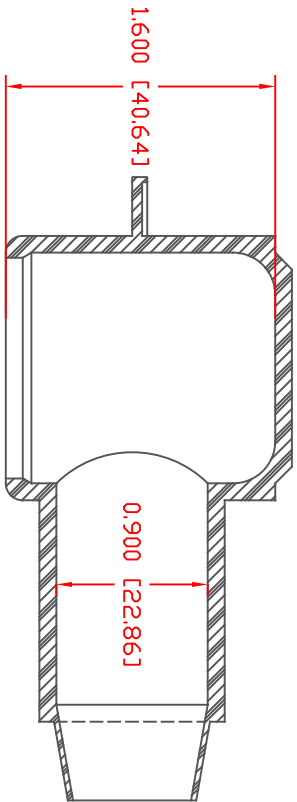

SEAL THICKNESS = .030" [8]



NL 4
Cable Gauges
3/0 - 4/0

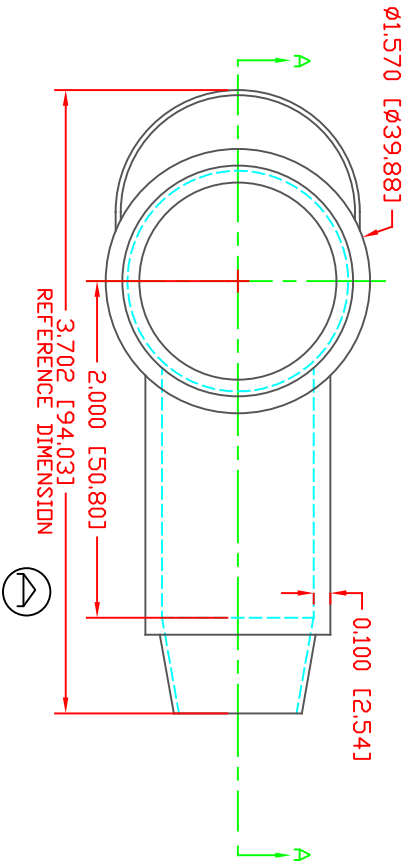

ALL DIMENSIONS GIVEN AS: In [mm]
MOLDED PARTS: ±.030" [±0.8mm]
HARDWARE ITEMS: ±.010" [±0.25mm]

MATERIAL PART NO: 1101650114
MATERIAL: PVC
VENDOR PART NO: 9812-65-BLACK
SHORE DUREMETER: #A" 10 SEC. 65
SPECIFIC GRAVITY: 1.34
ULT. ELONGATION %: 400
MELTING TEMP: 315-335 F [157-168 C]
BRITTLE TEMP: -54 F [-48 C]
Tensile Strength PSI: 1550 PSI
Dielectric Strength, v./mil: 453
UL Rating: V2

DO NOT SCALE

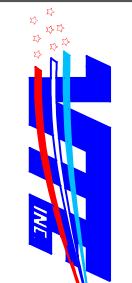

VTE Incorporated
5437 Robinson Road, P.O. Box 790
Pelleston, Michigan 49769
Telephone: 1-800-527-9256, 231-539-8000
FAX: 231-539-0914

REF:	DATE:	DRN BY:	JC	WEIGHT:
CUSTOMER DIMS	03-25-98	CHK'D BY:	JC	.067 LBS [30.2 g]
TITLE:	TERMINAL INSULATOR CAP			
MATERIAL:	PVC	PART NO:	234N4V14	
COLOR:	BLACK	DRG CLASS	REV D	