

THE INFORMATION CONTAINED IN THIS DRAWING IS THE SOLE PROPERTY OF VTE INCORPORATED. ANY REPRODUCTION IN PART OR WHOLE WITHOUT THE WRITTEN PERMISSION OF VTE INCORPORATED IS PROHIBITED.

P/N 31231N02 BASEPLATE

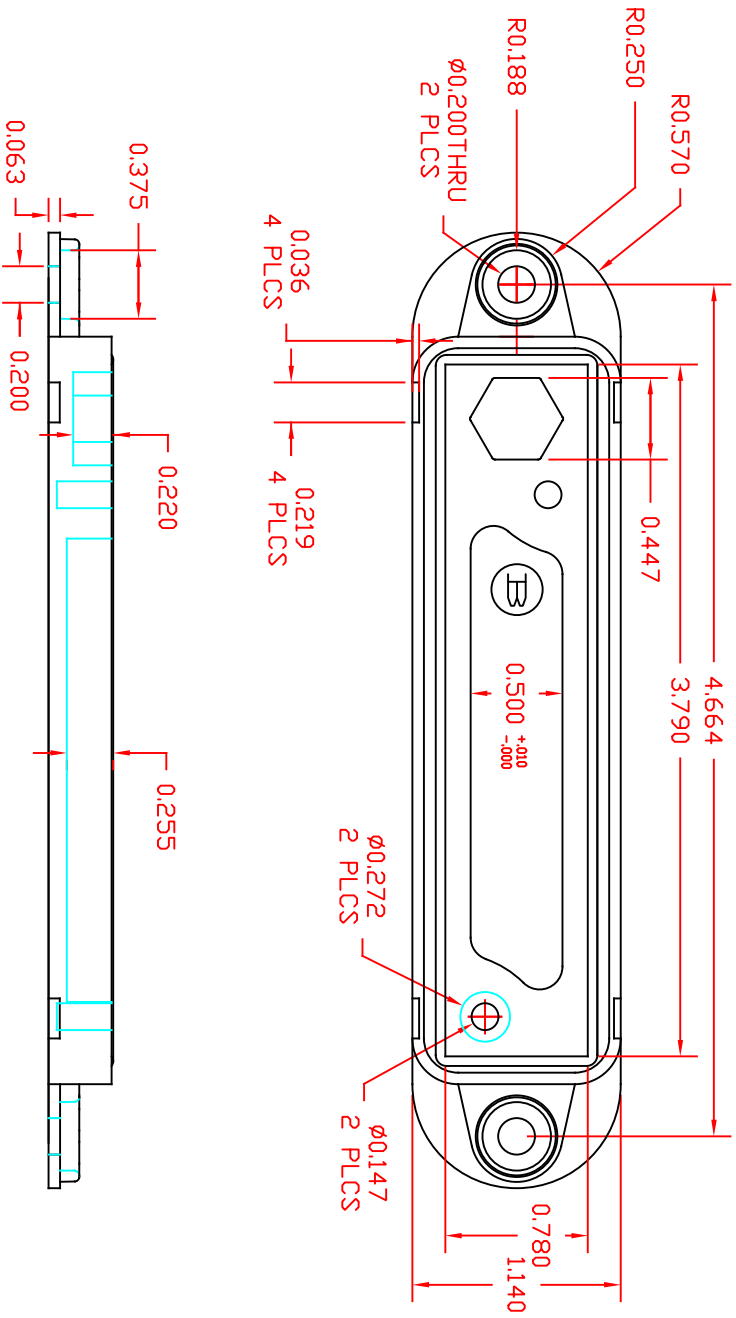

LR	REVISIONS	DATE	INT.
⊗	REVISED MATERIAL INFORMATION	07-17-18	RAS
⊕	ADDED CRITICAL DIMENSION	04/21/22	RAS

MATERIAL PART NO: 7111210502
 MATERIAL: GLASS FILLED NYLON
 VENDOR PART NO: HYLON N2015 HL NAT
 SPECIFIC GRAVITY: 1.23
 MELTING TEMP: 515 F [268 C]
 U.L. RATING: UL 94 HB

SCALE FACTOR : NONE
 ALL DIMENSIONS GIVEN AS: in [mm]
 TOLERANCES UNLESS OTHERWISE SPECIFIED :
 MOLD'D PARTS: ±.030" [±0.8mm]
 HARDWARE ITEMS: ±.010" [±0.25mm]



VTE Incorporated
 5437 Robinson Road, P.O. Box 790
 Pellston, Michigan 49769
 Telephone: 1-800-527-9256, 231-539-8000
 FAX: 231-539-0914

REF:	DATE:	DRN BY:	BRH	WEIGHT:
CUSTOMER DIMS	07JUN06	CHK'D BY:	BRH	18 G. / .040 LBS.
TITLE:	1/4" 4 WAY 5/16" CONTACT BLOCK BASE		SCALE:	
MATERIAL:	GLASS FILLED NYLON	PART NO:	31231N02	
COLOR:	RED	DRG CLASS	REV B	