

THE INFORMATION CONTAINED IN THIS DRAWING IS THE SOLE PROPERTY OF VTE INCORPORATED. ANY REPRODUCTION IN PART OR WHOLE WITHOUT THE WRITTEN PERMISSION OF VTE INCORPORATED IS PROHIBITED.

# P/N 31231 BASEPLATE

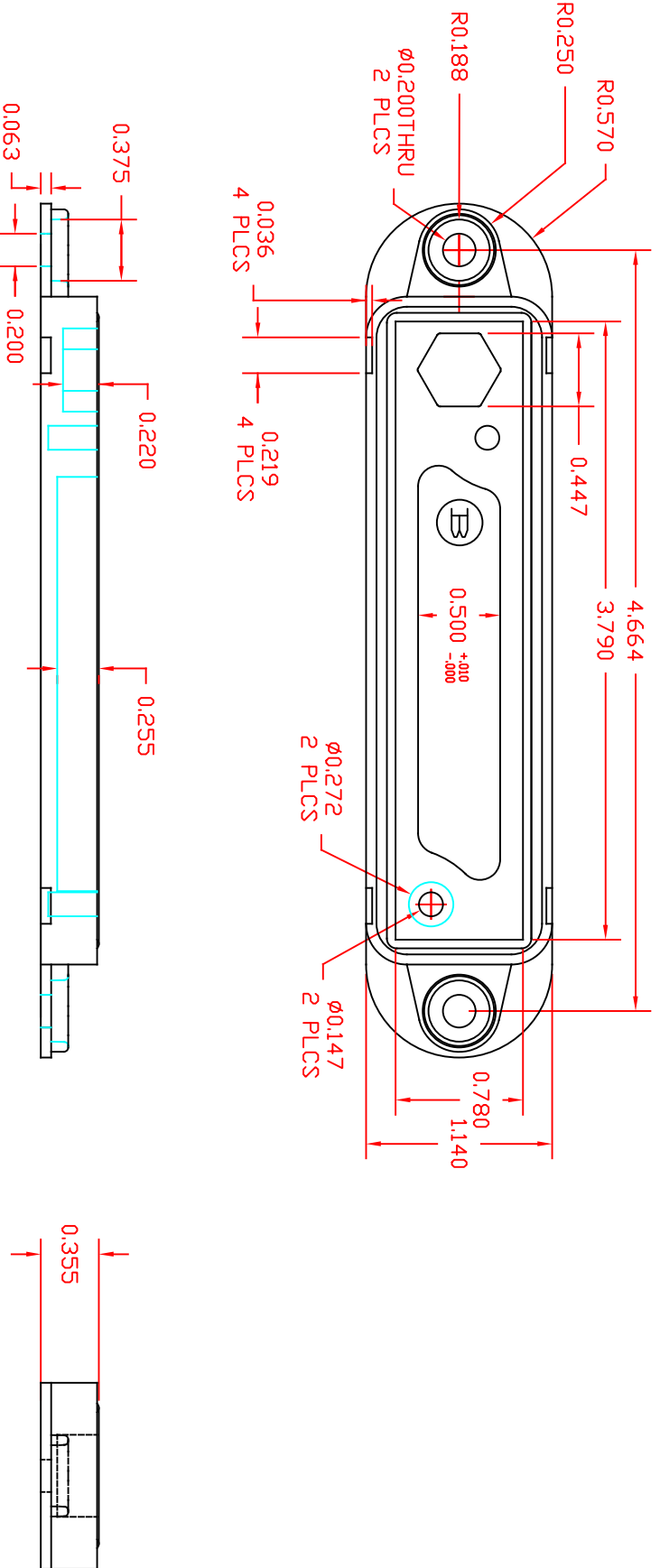

SCALE FACTOR : NONE  
 ALL DIMENSIONS GIVEN AS: IN [mm]  
 TOLERANCES UNLESS OTHERWISE SPECIFIED :  
 MOLDED PARTS: ±0.30° [±0.8mm]  
 HARDWARE ITEMS: ±.010° [±0.25mm]

MATERIAL PART NO: 111210514UL  
 MATERIAL: GLASS FILLED NYLON  
 VENDOR PART NO: NYLON N2015 HL BK  
 SPECIFIC GRAVITY: 1.23  
 MELTING TEMP: 515 F [268 C]  
 U.L. RATING: UL 94 HB

LR	REVISIONS	DATE	INT.
Δ	REVISED MATERIAL INFORMATION	07-17-18	RAS
⊕	ADDED CRITICAL DIMENSION	04/21/22	RAS

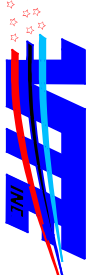

**VTE Incorporated**  
 5437 Robinson Road, P.O. Box 790  
 Pellston, Michigan 49769  
 Telephone: 1-800-527-9256, 231-539-8000  
 FAX: 231-539-0914

REF: DATE: DRN BY: BRH WEIGHT: 18 G. / .040 LBS.  
 CUSTOMER DIMS: 07JUN06 CHK'D BY: BRH SCALE:  
 TITLE: 1/4" 4 WAY 5/16" CONTACT BLOCK BASE

MATERIAL: GLASS FILLED NYLON PART NO: 31231N14  
 COLOR: BLACK DRG CLASS: REV B