

REVISIONS			
REV.	DESCRIPTION	DATE	APPROVED
A	Redrawn in Solidworks	7/3/2024	RAS
B	Added "Allowable Deflection" Note	7/3/2024	RAS

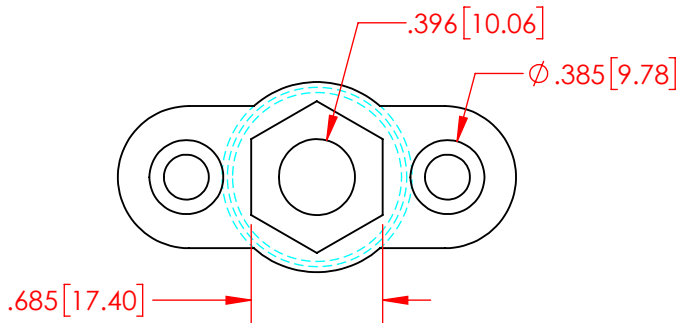
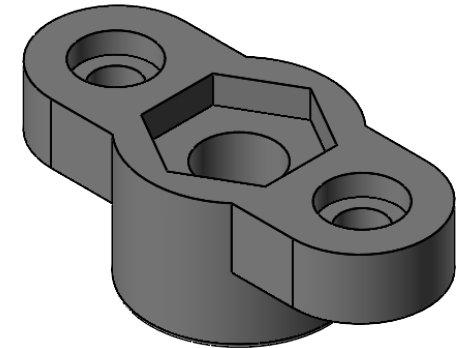
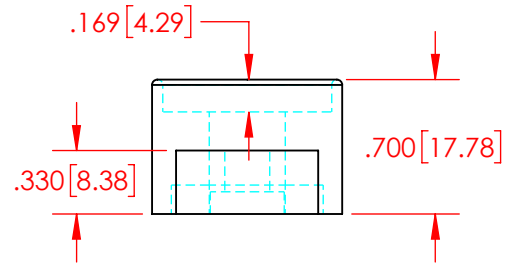
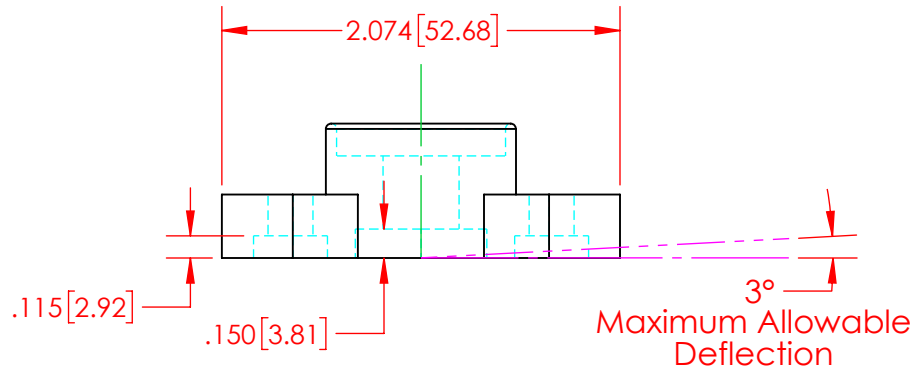
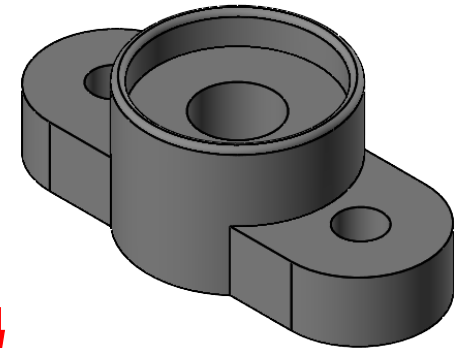
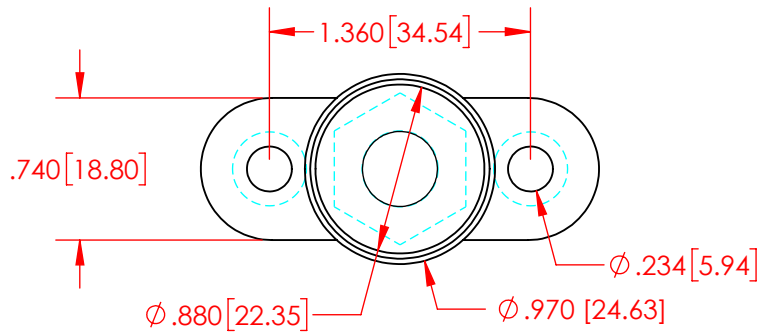

MATERIAL PART NO: 1111210514UL
 MATERIAL: GLASS FILLED NYLON
 VENDOR PART NO: NYLON N2015 HL BK
 SPECIFIC GRAVITY: 1.23
 MELTING POINT DEGREES F: 515
 MELTING POINT DEGREES C: 268
 MAXIMUM ACCEPTABLE MOISTURE CONTENT: .2%
 FLAME RATING: UL 94 HB

Part Weight: 0.021 Lbs. [9.6 g]
 Part Color : Black

ALL DIMENSIONS GIVEN AS : INCH [METRIC]
 TOLERANCES UNLESS OTHERWISE SPECIFIED :
 MOLDED PRODUCTS : ±.030" / ±0.8mm

PRINTED COPIES ARE NOT CONTROLLED

PROPRIETARY AND CONFIDENTIAL

THE INFORMATION CONTAINED IN THIS
 DRAWING IS THE SOLE PROPERTY OF
 VTE INCORPORATED. ANY REPRODUCTION
 IN PART OR AS A WHOLE WITHOUT THE WRITTEN
 PERMISSION OF VTE INCORPORATED PROHIBITED.



VTE INCORPORATED

5437 Robinson Road, P.O. Box 790
 Pellston, Michigan 49769 USA
 Telephone : 1-800-527-9256, 231-539-8000
 Fax : 231-539-0914, EFax : 231-344-5914

REV	B	NAME	DATE
		DRAWN BY:	RAS 7-3-24
SIZE	A	CHECKED BY:	
DO NOT SCALE DRAWING			

TITLE: 10mm Pass Thru Power Post Base

DWG. NO. **327D8N14**