

THE INFORMATION CONTAINED IN THIS DRAWING IS THE SOLE PROPERTY OF VTE INCORPORATED. ANY REPRODUCTION IN PART OR WHOLE WITHOUT THE WRITTEN PERMISSION OF VTE INCORPORATED IS PROHIBITED. VTE MAKES NO WARRANTY EXPRESSED OR IMPLIED, AS TO THE SUITABILITY OF A PRODUCT FOR ANY INTENDED USE. THE CUSTOMER SHALL BEAR THE SOLE RESPONSIBILITY OF DETERMINING THE SUITABILITY OF ANY VTE PRODUCT FOR ITS END USE.

LTR	REVISIONS	DATE	INT.
⊲	REVISED MATERIAL INFORMATION	7-17-18	RAS
⊳	ADDED 'ALLOWABLE DEFLECTION' NOTE	1-19-23	RAS

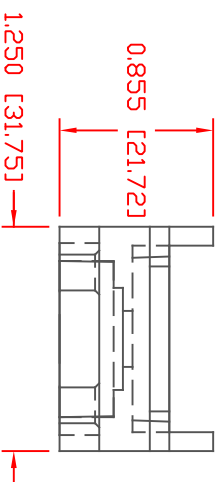
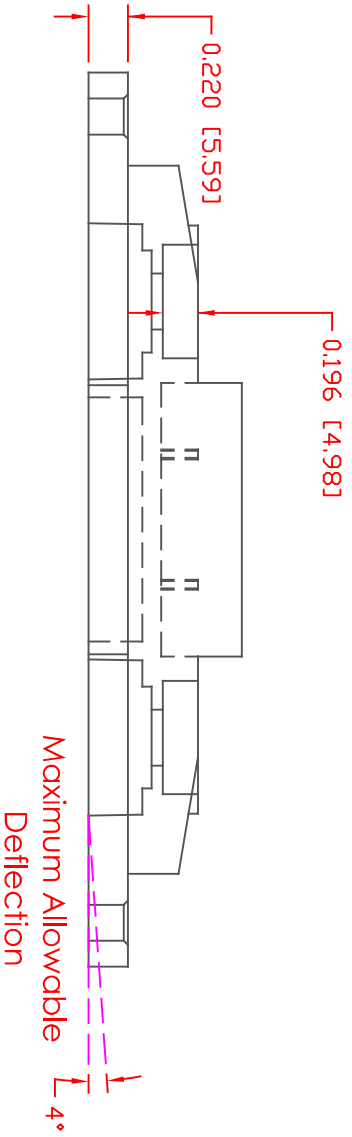
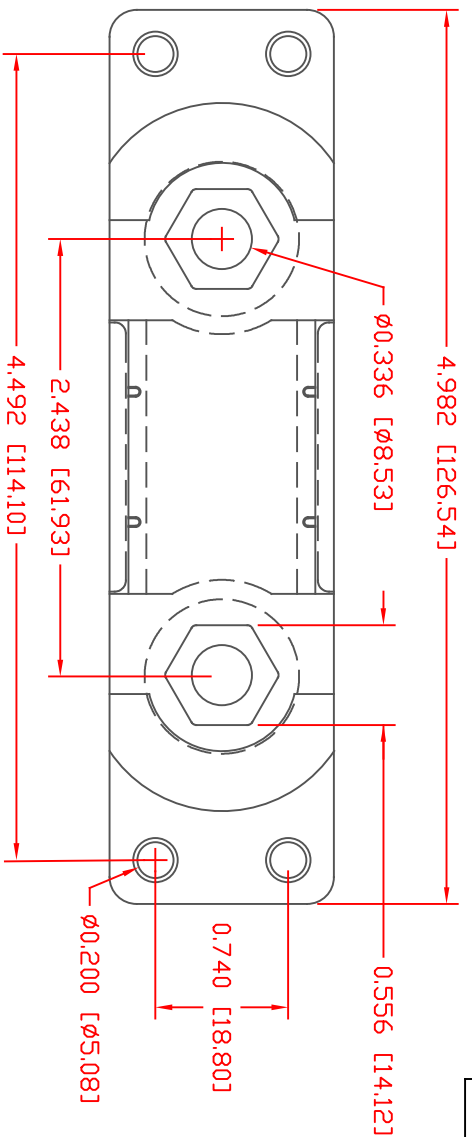

SCALE FACTOR : NONE
 ALL DIMENSIONS GIVEN AS: In [mm]
 TOLERANCES UNLESS OTHERWISE SPECIFIED :
 MOLDED PARTS: ±.030" [±0.8mm]
 HARDWARE ITEMS: ±.010" [±0.25mm]

MATERIAL PART NO: 7111210502
 MATERIAL: GLASS FILLED NYLON
 VENDOR PART NO: HYLON N2015 HL NAT
 SPECIFIC GRAVITY: 1.23
 MELTING TEMP: 515 F [268 C]
 U.L. RATING: 94 HB

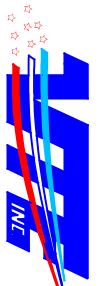

VTE Incorporated
 5437 Robinson Road, P.O. Box 790
 Pellston, Michigan 49769
 Telephone: 1-800-527-9256, 231-539-8000
 FAX: 231-539-0914

REF:	DATE:	DRN BY:	BRH	WEIGHT:
CUSTOMER DIMS	07-26-05	CHK'D BY:	BRH	.082 LBS [37.1 g]
TITLE: ANL FUSEHOLDER MOLDED BASE				
MATERIAL: GLASS FILLED NYLON	PART NO: 340N9N02			
COLOR: RED	DRG CLASS	REV B		

DD NOT SCALE