

THE INFORMATION CONTAINED IN THIS DRAWING IS THE SOLE PROPERTY OF VTE INCORPORATED. ANY REPRODUCTION IN PART OR WHOLE WITHOUT THE WRITTEN PERMISSION OF VTE INCORPORATED IS PROHIBITED. VTE MAKES NO WARRANTY, EXPRESSED OR IMPLIED, AS TO THE SUITABILITY OF A PRODUCT FOR ANY INTENDED USE. THE CUSTOMER SHALL BEAR THE SOLE RESPONSIBILITY OF DETERMINING THE SUITABILITY OF ANY VTE PRODUCT FOR ITS END USE.

LTR	REVISIONS	DATE	INT.
△	PRINT REVISED TO AGREE WITH MANUFACTURED PART	12-06-14	BRH
⊞	REVISED MATERIAL INFORMATION	7-17-18	RAS

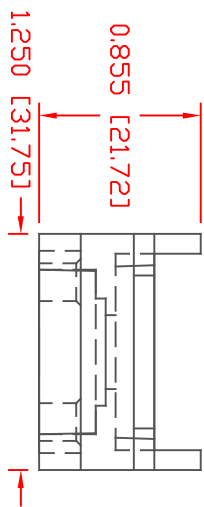
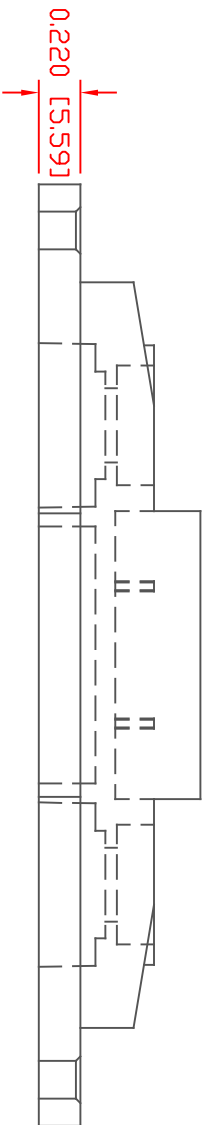
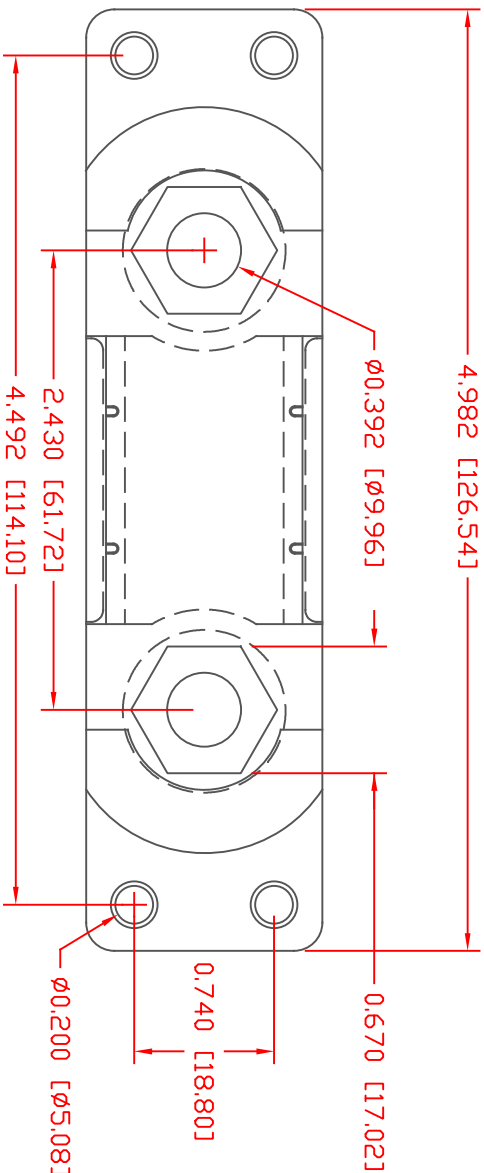

SCALE FACTOR : NONE  
 ALL DIMENSIONS GIVEN AS: in [mm]  
 TOLERANCES UNLESS OTHERWISE SPECIFIED :  
 MOLDED PARTS: ±.030" [±0.8mm]  
 HARDWARE ITEMS: ±.010" [±0.25mm]

MATERIAL PART NO:  
 MATERIAL:  
 VENDOR PART NO:  
 SPECIFIC GRAVITY:  
 MELTING TEMP:  
 U.L. RATING:

7111210502  
 GLASS FILLED NYLON  
 NYLON N2015 HL NAT  
 1.23  
 515 F [268 C]  
 UL 94 HB

DO NOT SCALE



**VTE Incorporated**  
 5437 Robinson Road, P.O. Box 790  
 Pellston, Michigan 49769  
 Telephone: 1-800-527-9256, 231-539-8000  
 FAX: 231-539-0914

REF:	DATE:	DRN BY:	BRH	WEIGHT:
CUSTOMER DIMS	01-11-07	CHK'D BY:	BRH	.081 LBS (37 g)
TITLE: ANL FUSEHOLDER METRIC BASE				
MATERIAL:	GLASS FILLED NYLON	PART NO: 340X10N02		
COLOR:	RED	DRG CLASS	REV B	