

THE INFORMATION CONTAINED IN THIS DRAWING IS THE SOLE PROPERTY OF VTE INCORPORATED. ANY REPRODUCTION IN PART OR WHOLE WITHOUT THE WRITTEN PERMISSION OF VTE INCORPORATED, VTE MAKES NO WARRANTY, EXPRESSED OR IMPLIED, AS TO THE SUITABILITY OF A PRODUCT FOR ANY INTENDED USE. THE CUSTOMER SHALL BEAR THE SOLE RESPONSIBILITY OF DETERMINING THE SUITABILITY OF ANY VTE PRODUCT FOR ITS END USE.

LTR	REVISIONS	DATE	INT.
△	REVISED MATERIAL INFORMATION	7-17-18	RAS
⊞	REMOVED MAKE FROM P/N 3437 ² NOTE	5-31-24	RAS

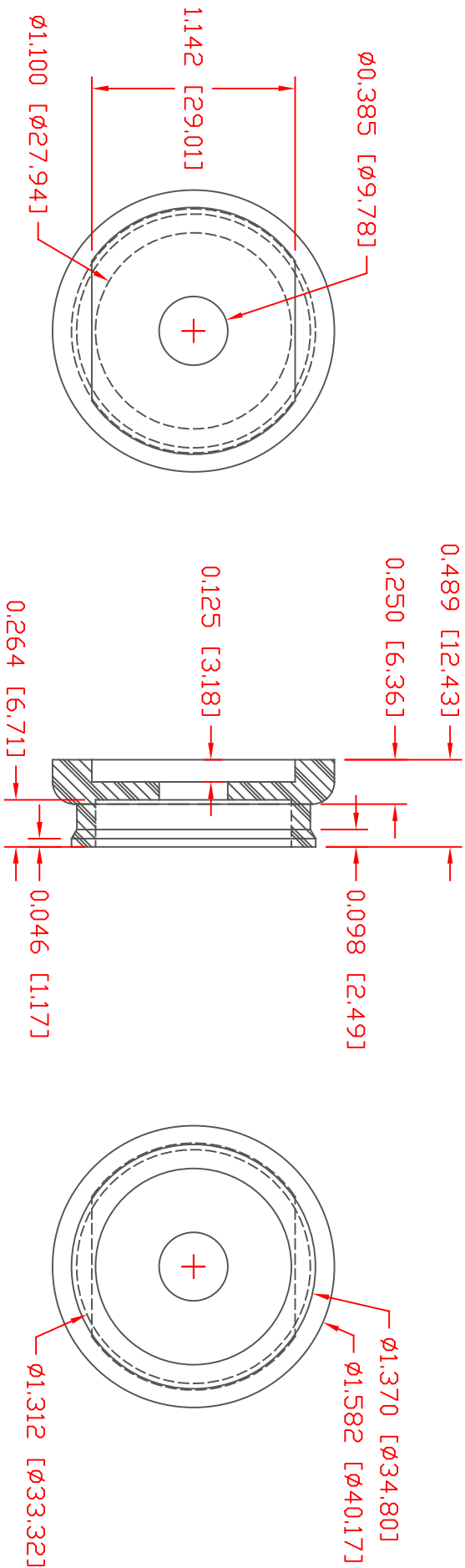

SCALE FACTOR : NONE
 ALL DIMENSIONS GIVEN AS: in [mm]
 TOLERANCES UNLESS OTHERWISE SPECIFIED :
 MOLDED PARTS: ±.030" [±0.8mm]
 HARDWARE ITEMS: ±.010" [±0.25mm]

MATERIAL PART NO:
 MATERIAL:
 VENDOR PART NO:
 SPECIFIC GRAVITY:
 MELTING TEMP:
 U.L. RATING:

111210514UL
 GLASS FILLED NYLON
 HYLON N2015 HL BK
 1.23
 515 F [268 C]
 UL 94 HB



VTE Incorporated
 5437 Robinson Road, P.O. Box 790
 Pellston, Michigan 49769
 Telephone: 1-800-527-9256, 231-539-8000
 FAX: 231-539-0914

REF:	DATE:	DRN BY:	BRH	WEIGHT:
CUSTOMER DIMS	1-08-03	CHK'D BY:	BRH	
TITLE: OUTER PANEL BUSHING FOR 3/8" STUD (WEATHERPROOF)				
MATERIAL: GLASS FILLED NYLON	PART NO:			
COLOR: BLACK	DRG CLASS	REV B	3438N14	