

THE INFORMATION CONTAINED IN THIS DRAWING IS THE SOLE PROPERTY OF VTE INCORPORATED. ANY REPRODUCTION IN PART OR WHOLE WITHOUT THE WRITTEN PERMISSION OF VTE INCORPORATED IS PROHIBITED. VTE MAKES NO WARRANTY, EXPRESSED OR IMPLIED, AS TO THE SUITABILITY OF A PRODUCT FOR ANY INTENDED USE. THE CUSTOMER SHALL BEAR THE SOLE RESPONSIBILITY OF DETERMINING THE SUITABILITY OF ANY VTE PRODUCT FOR ITS END USE.

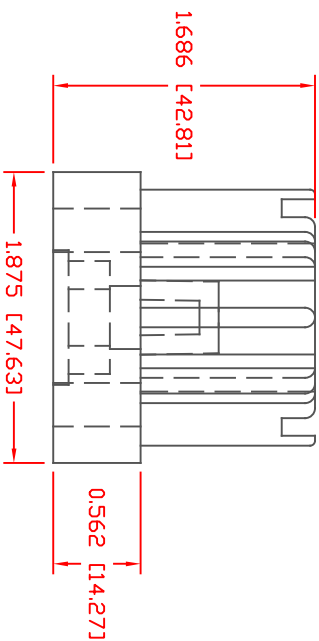
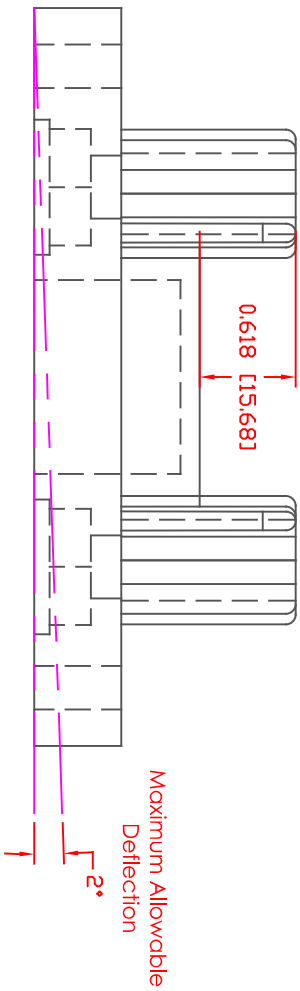
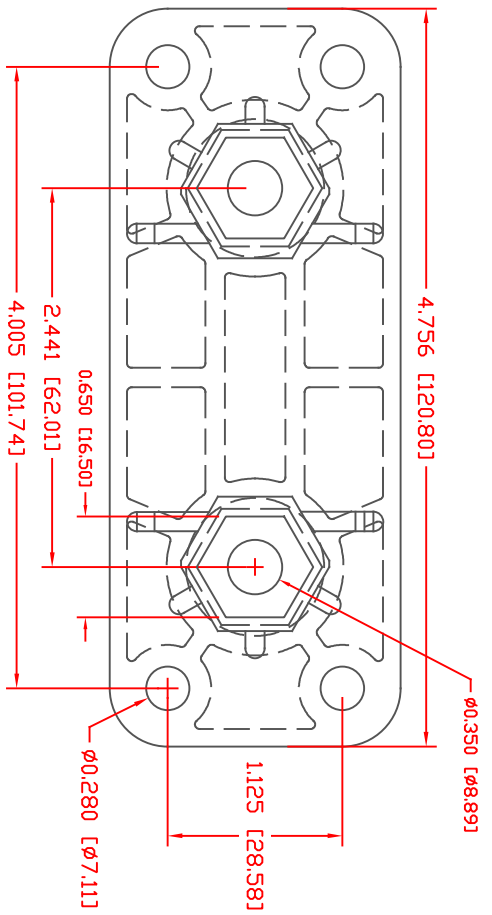

SCALE FACTOR : NONE
 ALL DIMENSIONS GIVEN AS: in [mm]
 TOLERANCES UNLESS OTHERWISE SPECIFIED :
 MOLDED PARTS: ±.030" [±0.8mm]
 HARDWARE ITEMS: ±.010" [±0.25mm]

MATERIAL PART NO: 1111210514UL
 MATERIAL: GLASS FILLED NYLON
 VENDOR PART NO: HYLON N2015 HL BK
 SPECIFIC GRAVITY: 1.23
 MELTING TEMP: 515 F [268 C]
 U.L. RATING: UL 94 HB

LTR.	REVISIONS	DATE	INT.
⊲	REVISED MATERIAL INFORMATION	7-17-18	RAS
⊳	ADDED 'ALLOWABLE DEFLECTION' NOTE	8-19-24	RAS

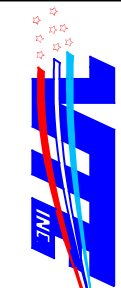

VTE Incorporated
 5437 Robinson Road, P.O. Box 790
 Pellston, Michigan 49769
 Telephone: 1-800-527-9256, 231-539-8000
 FAX: 231-539-0914

REF:	DATE:	DRN BY:	BRH	WEIGHT:
CUSTOMER DIMS:	07-20-07	CHK'D BY:		1.82 LBS [82.7 g]
TITLE: FUSE HOLDER, HI AMP ANL 5/16" AND 8MM				
MATERIAL: GLASS FILLED NYLON				PART NO:
COLOR: BLACK				353N7N14
DRG CLASS: REV B				

DD NOT SCALE