

REVISIONS			
REV.	DESCRIPTION	DATE	APPROVED
C	Redrawn in Solidworks	12/29/2022	RAS

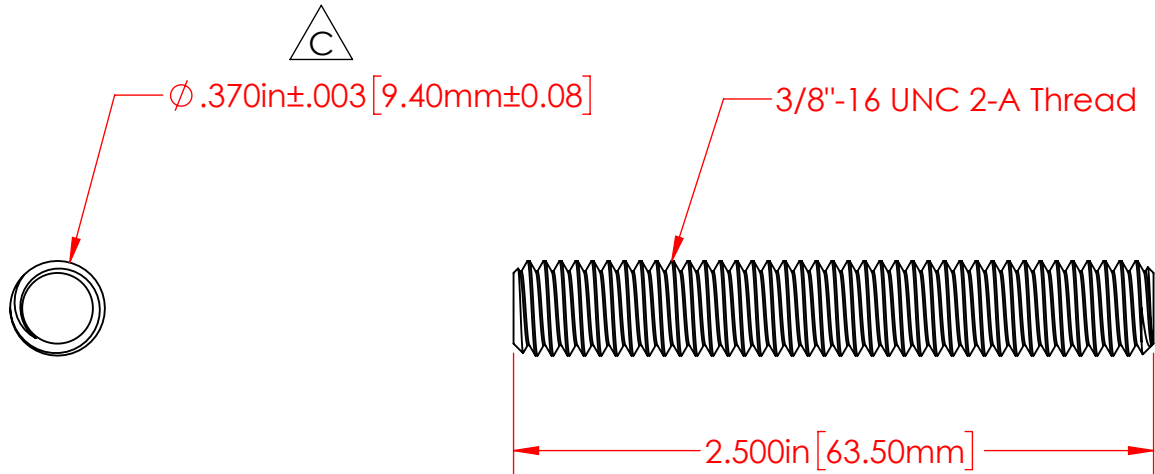
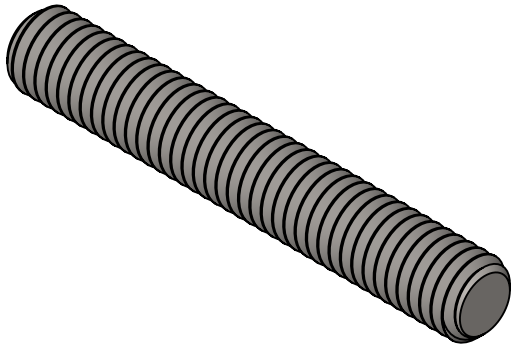

P/N 3742-011  
 3/8"-16 Threaded Stud  
 Nickel Plated Mild Steel

Part Material :  
 Nickel Plated Mild Steel

ALL DIMENSIONS GIVEN AS : INCH [METRIC]  
 TOLERANCES UNLESS OTHERWISE SPECIFIED :  
 HARDWARE PRODUCTS : ±.010" / ±0.25mm

PRINTED COPIES ARE NOT CONTROLLED  
**PROPRIETARY AND CONFIDENTIAL**  
 THE INFORMATION CONTAINED IN THIS  
 DRAWING IS THE SOLE PROPERTY OF  
 VTE INCORPORATED. ANY REPRODUCTION  
 IN PART OR AS A WHOLE WITHOUT THE WRITTEN  
 PERMISSION OF VTE INCORPORATED PROHIBITED.



**VTE INCORPORATED**

5437 Robinson Road, P.O. Box 790  
 Pellston, Michigan 49769 USA  
 Telephone : 1-800-527-9256, 231-539-8000  
 Fax : 231-539-0914, Efax : 231-344-5914

REV	<b>C</b>	NAME	DATE
		DRAWN BY:	RAS 12-29-22
SIZE	<b>A</b>	CHECKED BY:	
DO NOT SCALE DRAWING			

TITLE:	3/8"-16 Double Ended Stud
DWG. NO.	<b>3742-011</b>