

THE INFORMATION CONTAINED IN THIS DRAWING IS THE SOLE PROPERTY OF VTE INCORPORATED. ANY REPRODUCTION IN PART OR WHOLE WITHOUT THE WRITTEN PERMISSION OF VTE INCORPORATED IS PROHIBITED. VTE MAKES NO WARRANTY, EXPRESSED OR IMPLIED, AS TO THE SUITABILITY OF A PRODUCT FOR ANY INTENDED USE. THE CUSTOMER SHALL BEAR THE SOLE RESPONSIBILITY OF DETERMINING THE SUITABILITY OF ANY VTE PRODUCT FOR ITS END USE.

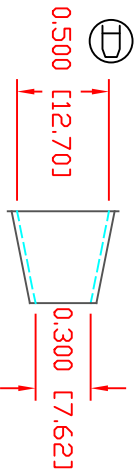

SECTION A-A
TYP. WALL THICKNESS = .060" [1.51]

SEAL THICKNESS = .030" [.8]
SEAL TOLERANCE: +.030/-0.10 [+8/-25]
WIRE GAGES: 8 - 2

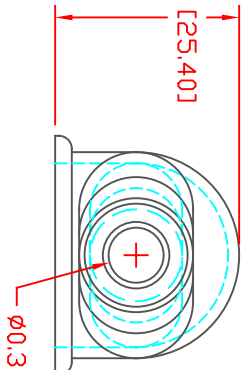
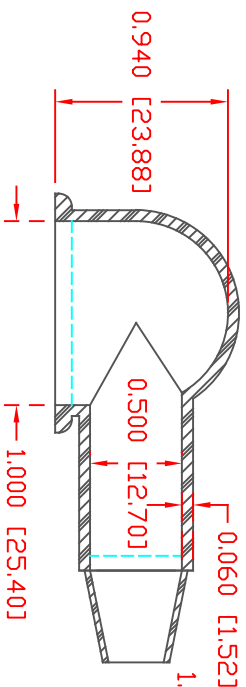
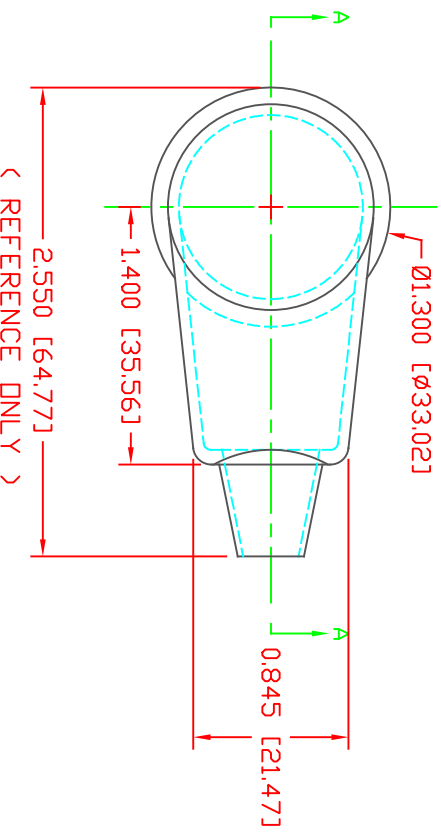

< REFERENCE ONLY >

VTE PART NO: 1103640114
 MATERIAL: SANTOPRENE 101-64
 VENDOR PART NO: TPE AES 101-64 BK SANTOPRENE
 SHORE DUREMETER: 'A' 15 SEC. 69
 SPECIFIC GRAVITY: .97
 ULT. ELONGATION %: 450
 MELTING TEMP: 380-450 F [193-232 C]
 BRITTLE TEMP: -76 F [-60 C]
 TENSILE STRENGTH PSI: 1020
 DIELECTRIC STRENGTH, V./mil: 680
 U.L. RATING: HB

LR.	REVISIONS	DATE	INT.
A	UPDATED DIMENSIONS	11-12-15	RAS
B	ADDED 'REFERENCE ONLY' NOTE TO DIMENSION	7-20-22	RAS
C	UPDATED MATERIAL INFORMATION	8-02-22	RAS
D	MOVED DIMENSION FROM DD. TO LD OF CABLE ENTRY	10-29-24	RAS

SCALE FACTOR : NONE
 ALL DIMENSIONS GIVEN AS: In [mm]
 TOLERANCES UNLESS OTHERWISE SPECIFIED :
 MOLDED PARTS: ±.030" [±0.8mm]
 ALL ANGLES ARE ± 1 DEGREE

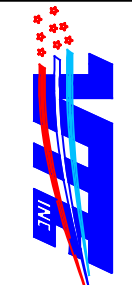

VTE Incorporated
 5437 Robinson Road, P.O. Box 790
 Pellston, Michigan 49769
 Telephone: 1-800-527-9256, 231-539-8000
 FAX: 231-539-0914

REF:	DATE:	DRN BY:	JC	WEIGHT:	
CUSTOMER DIMS	03-26-98	CHK'D BY:	JC	.019 LBS [8.48 g]	
TITLE:	EYELET TERMINAL INSULATOR				
MATERIAL:	SANTOPRENE	PART NO:	405N2T14		
COLOR:	BLACK	DRG CLASS	REV D		