

THE INFORMATION CONTAINED IN THIS DRAWING IS THE SOLE PROPERTY OF VTE INCORPORATED. ANY REPRODUCTION IN PART OR WHOLE WITHOUT THE WRITTEN PERMISSION OF VTE INCORPORATED IS PROHIBITED. VTE MAKES NO WARRANTY, EXPRESSED OR IMPLIED, AS TO THE SUITABILITY OF A PRODUCT FOR ANY INTENDED USE. THE CUSTOMER SHALL BEAR THE SOLE RESPONSIBILITY OF DETERMINING THE SUITABILITY OF ANY VTE PRODUCT FOR ITS END USE.

LTR	REVISIONS	DATE	INT.
▲	UPDATED .080 [2.01] TD .090 [2.3]	3-8-17	RAS

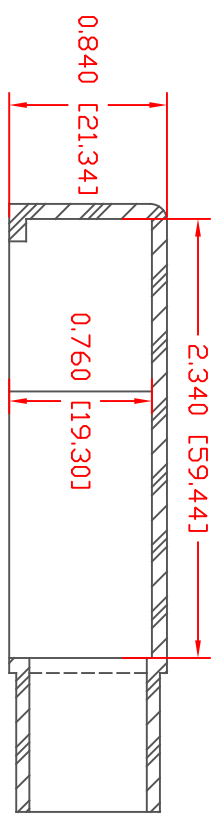
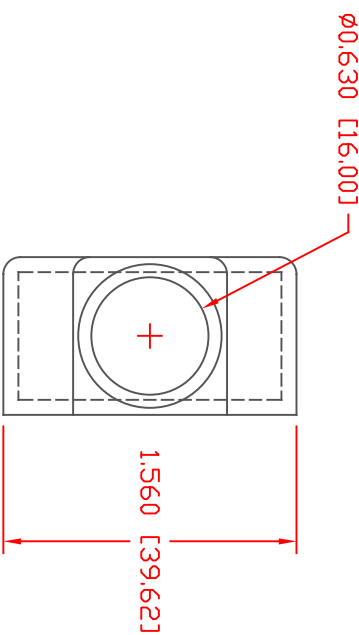
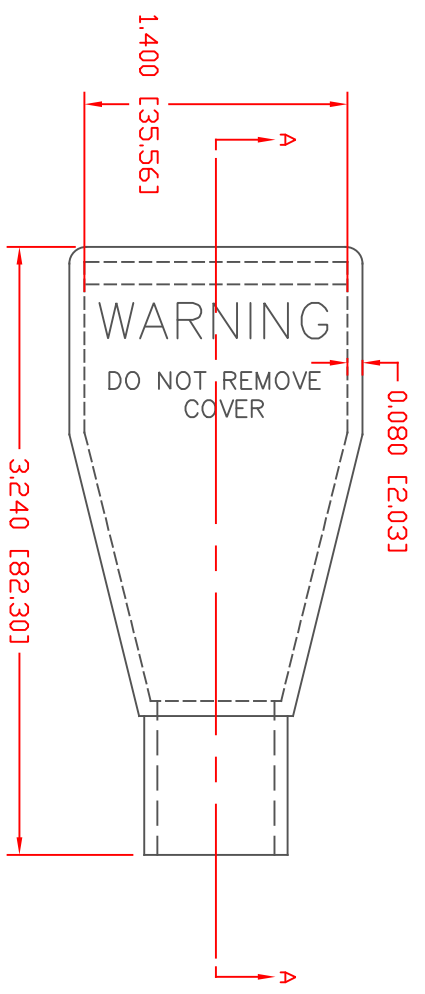

VTE PART NO: 1101700114  
 MATERIAL: PVC  
 VENDOR PART NO: 7843-70-BLACK  
 SHORE DUREMETER: "A" 10 SEC. 70  
 SPECIFIC GRAVITY: 1.34  
 ULT. ELONGATION %: 350  
 MELTING TEMP: 320-340 F [160-171 C]  
 BRITTLE TEMP: -22 F [-30 C]  
 TENSILE STRENGTH PSI: 1500 PSI  
 DIELECTRIC STRENGTH, V./mil: 500  
 U.L. RATING: V0

DO NOT SCALE

ALL DIMENSIONS GIVEN AS: in [mm]  
 MOLDED PARTS: ±.030" [±0.8mm]



**VTE Incorporated**  
 5437 Robinson Road, P.O. Box 790  
 Pellston, Michigan 49769  
 Telephone: 1-800-527-9256, 231-539-8000  
 FAX: 231-539-0914

REF:	DATE:	DRN BY:	JC	WEIGHT:
CUSTOMER DIMS	03-27-98	CHK'D BY:	JC	.037 LBS [16.7 g]
TITLE:	BATTERY CABLE BOOT			
MATERIAL:	PVC	PART NO.	415N9F14	
COLOR:	BLACK	DRG CLASS	REV A	