

THE INFORMATION CONTAINED IN THIS DRAWING IS THE SOLE PROPERTY OF VTE INCORPORATED. ANY REPRODUCTION IN PART OR WHOLE WITHOUT THE WRITTEN PERMISSION OF VTE INCORPORATED IS PROHIBITED. VTE MAKES NO WARRANTY, EXPRESSED OR IMPLIED, AS TO THE SUITABILITY OF A PRODUCT FOR ANY INTENDED USE. THE CUSTOMER SHALL BEAR THE SOLE RESPONSIBILITY OF DETERMINING THE SUITABILITY OF ANY VTE PRODUCT FOR ITS END USE.

LTG.	REVISIONS	DATE	INT.

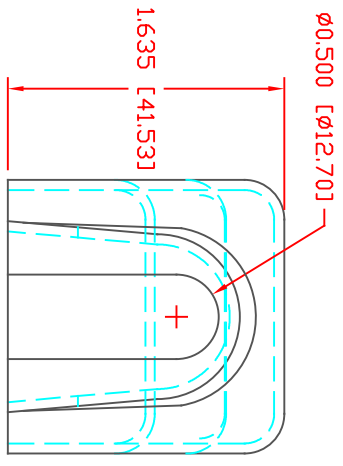

1/0 (.500" Ø)
N6

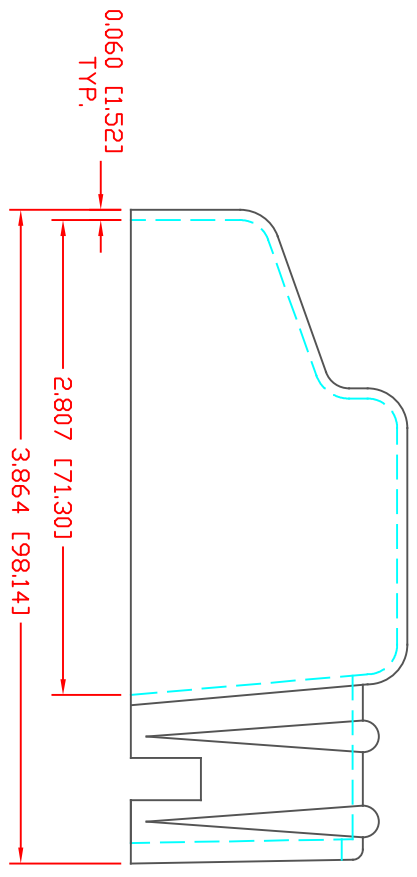

SCALE FACTOR : NONE
ALL DIMENSIONS GIVEN AS: In [mm]
TOLERANCES UNLESS OTHERWISE SPECIFIED :
MOLDED PARTS: ±.030" [±0.8mm]
HARDWARE ITEMS: ±.010" [±0.25mm]

VTE PART NO: 1101900114
MATERIAL: PVC
VENDOR PART NO: 9067-90 FR BLACK
SHORE DUREMETER: 70
SPECIFIC GRAVITY: 1.34
ULT. ELONGATION %: 350
MELTING TEMP: 320-340 F [160-171 C]
BRITTLE TEMP: -22 F [-30 C]
Tensile Strength PSI: 1550
Dielectric Strength, v./mil: 553
UL Rating: V0

DO NOT SCALE



VTE Incorporated
5437 Robinson Road, P.O. Box 790
Pellston, Michigan 49769
Telephone: 1-800-527-9256, 231-539-8000
FAX: 231-539-0914

REF.	DATE:	DRN BY:	BRH	WEIGHT:
CUSTOMER DIMS	01-01-98	CHK'D BY:	BRH	.062 LBS [28.2 g]
TITLE: BATTERY TERMINAL INSULATOR				
MATERIAL: PVC		PART NO: 455N6V14		
COLOR: BLACK		DRG CLASS		