

THE INFORMATION CONTAINED IN THIS DRAWING IS THE SOLE PROPERTY OF VTE INCORPORATED. ANY REPRODUCTION IN PART OR WHOLE WITHOUT THE WRITTEN PERMISSION OF VTE INCORPORATED IS PROHIBITED. VTE MAKES NO WARRANTY, EXPRESSED OR IMPLIED, AS TO THE SUITABILITY OF A PRODUCT FOR ANY INTENDED USE. THE CUSTOMER SHALL BEAR THE SOLE RESPONSIBILITY OF DETERMINING THE SUITABILITY OF ANY VTE PRODUCT FOR ITS END USE.

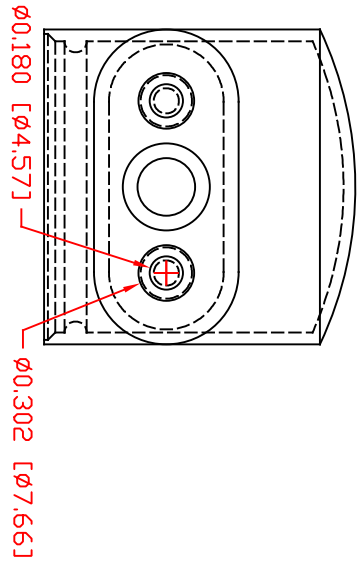
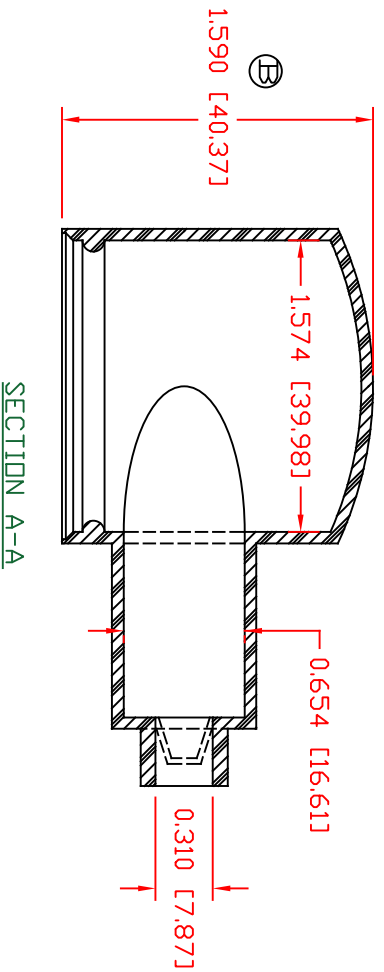
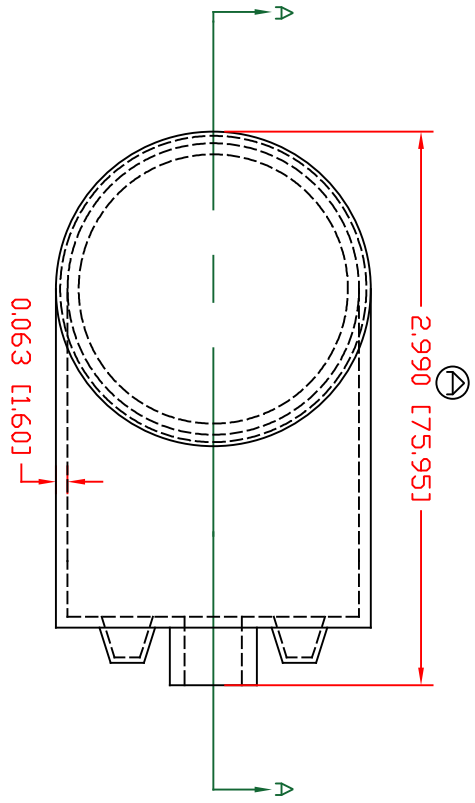

TYP. WALL THICKNESS = 1.5

LR	REVISIONS	DATE	INT.
A	REVISED DIMENSION FROM 3.010"	07-07-20	EJE
B	UPDATED DIMENSION FROM 1.680 [42.67]	11-27-24	RAS

SCALE FACTOR: 1 NONE  
 ALL DIMENSIONS GIVEN AS: In [mm]  
 TOLERANCES UNLESS OTHERWISE SPECIFIED:  
 MOLDED PARTS: ±.030" [±0.8mm]  
 ALL ANGLES ARE ± 1 DEGREE

**VTE Incorporated**  
 5437 Robinson Road, P.O. Box 790  
 Pellston, Michigan 49769  
 Telephone: 1-800-527-9256, 231-539-8000  
 FAX: 231-539-0914

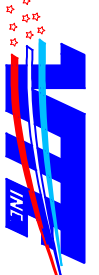

MATERIAL PART NO: 1101650114  
 MATERIAL: PVC  
 VENDOR PART NO: 9812-65-BLACK  
 SHORE DUREMETER: "A" 10 SEC. 65  
 SPECIFIC GRAVITY: 1.34  
 ULT. ELONGATION %: 400  
 MELTING TEMP: 315-335 F [157-168 C]  
 BRITTLE TEMP: -54 F [-48 C]  
 TENSILE STRENGTH PSI: 1550  
 DIELECTRIC STRENGTH, V./mil: 453  
 U.L. RATING: V2

REF:	DATE:	DRN BY: JC	WEIGHT:
	04-07-1998	CHK'D BY: EJE	0.058 lbs/26.44 g
TITLE: STYLE 1 MARINE BOOT UPPER			
MATERIAL:	PVC	PART NO:	600N1V14
COLOR:	BLACK	DRG CLASS:	REV B