

THE INFORMATION CONTAINED IN THIS DRAWING IS THE SOLE PROPERTY OF VTE INCORPORATED. ANY REPRODUCTION IN PART OR WHOLE WITHOUT THE WRITTEN PERMISSION OF VTE INCORPORATED IS PROHIBITED. VTE MAKES NO WARRANTY, EXPRESSED OR IMPLIED, AS TO THE SUITABILITY OF A PRODUCT FOR ANY INTENDED USE. THE CUSTOMER SHALL BEAR THE SOLE RESPONSIBILITY OF DETERMINING THE SUITABILITY OF ANY VTE PRODUCT FOR ITS END USE.

LR	REVISIONS	DATE	INT.
A	CHANGED DIMENSION FROM 3.010"	07-07-20	EJE
B	UPDATED DIMENSION FROM 1.680 [42.67]	11-27-24	RAS

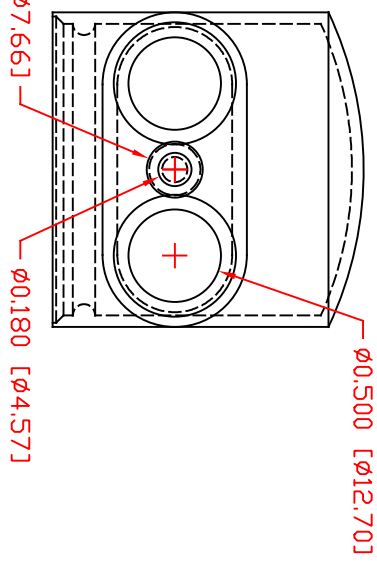
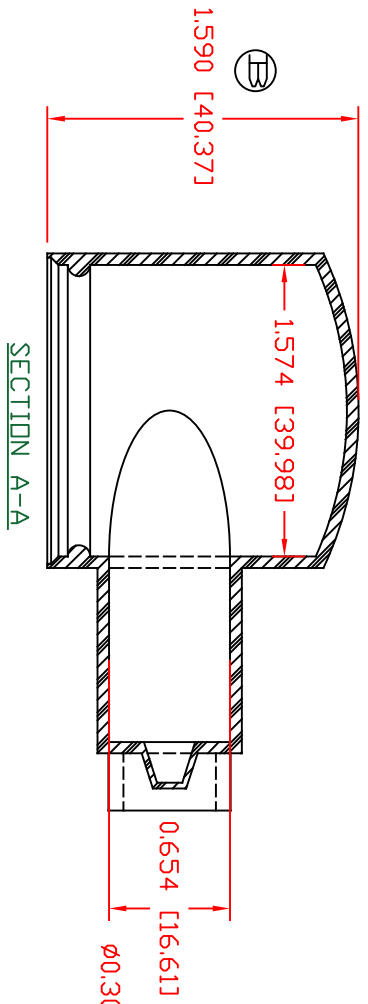
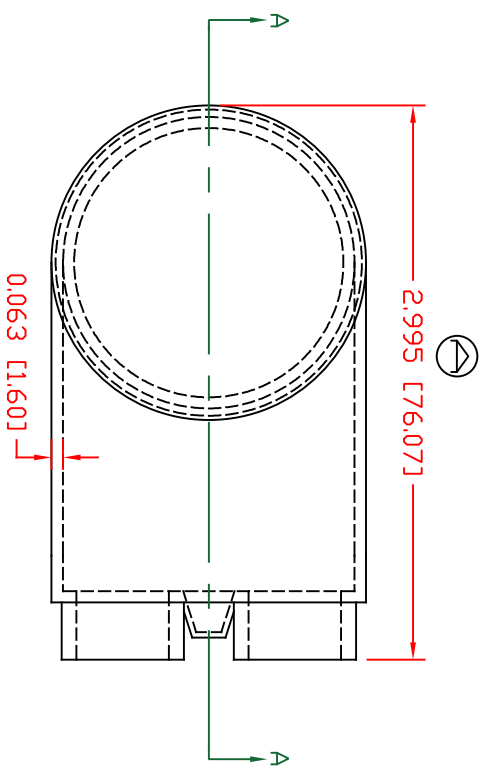

TYP. WALL THICKNESS = 1.5

MATERIAL PART NO:  
 MATERIAL:  
 VENDOR PART NO:  
 SHORE DUREMETER:  
 SPECIFIC GRAVITY:  
 ULT. ELONGATION %:  
 MELTING TEMP:  
 BRITTLE TEMP:  
 TENSILE STRENGTH PSI:  
 DIELECTRIC STRENGTH, V./mil  
 U.L. RATING:

1101650114  
 PVC  
 9812-65-BLACK  
 "A" 10 SEC. 65  
 1.34  
 400  
 315-335 F [157-168 C]  
 -54 F [-48 C]  
 1550 PSI  
 453  
 V/2

SCALE FACTOR : NONE  
 ALL DIMENSIONS GIVEN AS [in, mm]  
 TOLERANCES UNLESS OTHERWISE SPECIFIED :  
 MOLDED PARTS: ±0.30° [±0.8mm]  
 ALL ANGLES ARE ± 1 DEGREE



VTE Incorporated  
 5437 Robinson Road, P.O. Box 790  
 Pellston, Michigan 49769  
 Telephone: 1-800-927-9256, 231-539-8000  
 FAX: 231-539-0914

REF:	DATE:	DRN BY:	JC	WEIGHT:
	04-08-1998	CHK'D BY:	EJE	0.053 lbs [23.99 g]
TITLE:	STYLE 4 MARINE BODT UPPER			
MATERIAL:	PVC	PART NO:	600N4V14	
COLOR:	BLACK	DRG CLASS		