

THE INFORMATION CONTAINED IN THIS DRAWING IS THE SOLE PROPERTY OF VTE INCORPORATED. ANY REPRODUCTION IN PART OR WHOLE WITHOUT THE WRITTEN PERMISSION OF VTE INCORPORATED IS PROHIBITED. VTE MAKES NO WARRANTY, EXPRESSED OR IMPLIED, AS TO THE SUITABILITY OF A PRODUCT FOR ANY INTENDED USE. THE CUSTOMER SHALL BEAR THE SOLE RESPONSIBILITY OF DETERMINING THE SUITABILITY OF ANY VTE PRODUCT FOR ITS END USE.

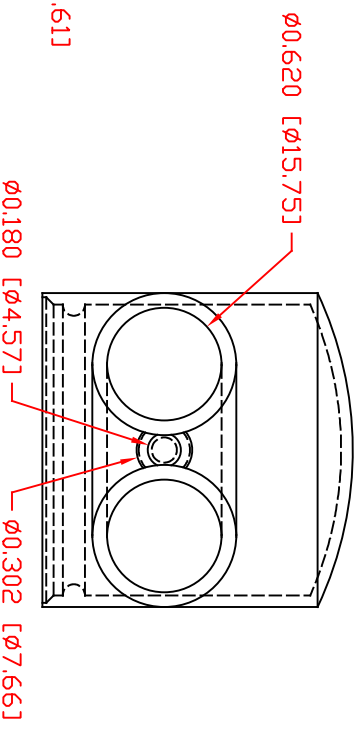
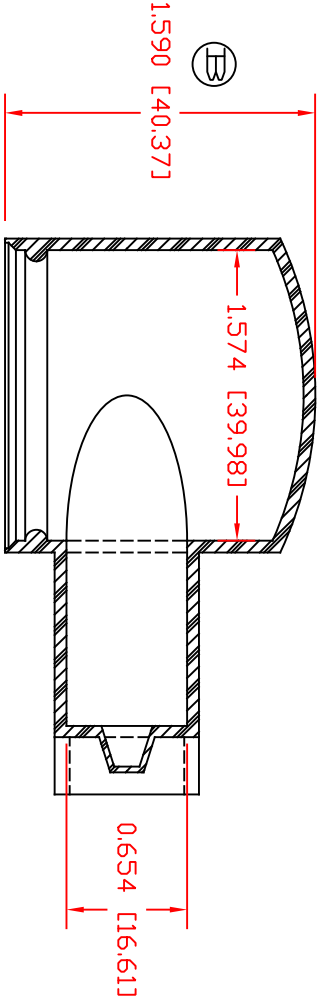
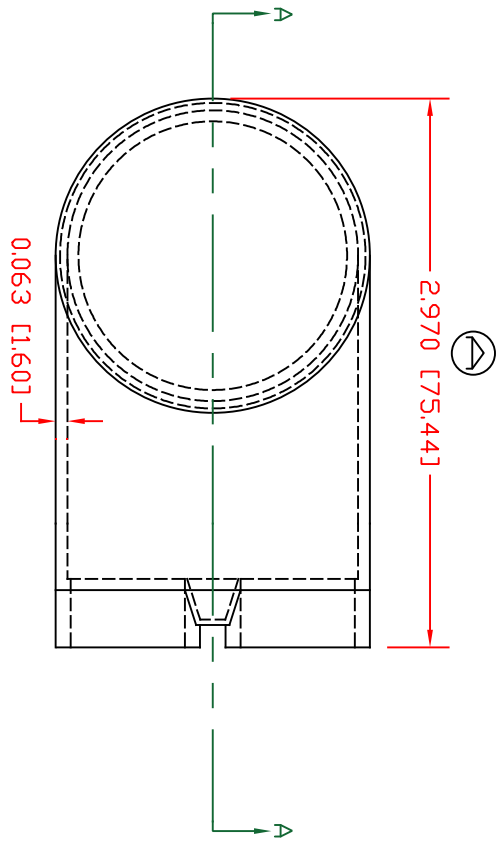

TYP. WALL THICKNESS = 0.063 [1.60]

SECTION A-A

MATERIAL PART NO:
 MATERIAL:
 VENDOR PART NO:
 SHORE DUREMETER:
 SPECIFIC GRAVITY:
 ULT. ELONGATION %:
 MELTING TEMP:
 BRITTLE TEMP:
 TENSILE STRENGTH PSI:
 DIELECTRIC STRENGTH, V./mil
 U.L. RATING:

1101650102
 PVC
 9812-65-RED 683
 'A' 10 SEC. 65
 1.34
 400
 315-335 F [157-168 C]
 -54 F [-48 C]
 1550 PSI
 511
 V/2

SCALE FACTOR : NONE
 ALL DIMENSIONS GIVEN AS: In. [mm]
 TOLERANCES UNLESS OTHERWISE SPECIFIED :
 MOLDED PARTS: ±0.30° [±0.8mm]
 ALL ANGLES ARE ± 1 DEGREE



VTE Incorporated
 5437 Robinson Road, P.O. Box 790
 Pellston, Michigan 49769
 Telephone: 1-800-527-9256, 231-539-8000
 FAX: 231-539-0914

REF:	DATE:	DRN BY:	JC	WEIGHT:
	04-08-1998	CHK'D BY:	EJE	0.055 lbs [24.80 g]
TITLE:	STYLE 6 MARINE BOOT UPPER			
MATERIAL:	PVC	PART NO:		
COLOR:	RED	DRG CLASS	REV B	600N6V02

LR.	REVISIONS	DATE	INT.
⊖	CHANGED DIMENSION FROM 3.010"	07-07-20	EJE
⊕	UPDATED DIMENSION FROM 1.680 [42.67]	11-27-24	RAS