

THE INFORMATION CONTAINED IN THIS DRAWING IS THE SOLE PROPERTY OF VTE INCORPORATED. ANY REPRODUCTION IN PART OR WHOLE WITHOUT THE WRITTEN PERMISSION OF VTE INCORPORATED IS PROHIBITED. VTE MAKES NO WARRANTY, EXPRESSED OR IMPLIED, AS TO THE SUITABILITY OF A PRODUCT FOR ANY INTENDED USE. THE CUSTOMER SHALL BEAR THE SOLE RESPONSIBILITY OF DETERMINING THE SUITABILITY OF ANY VTE PRODUCT FOR ITS END USE.

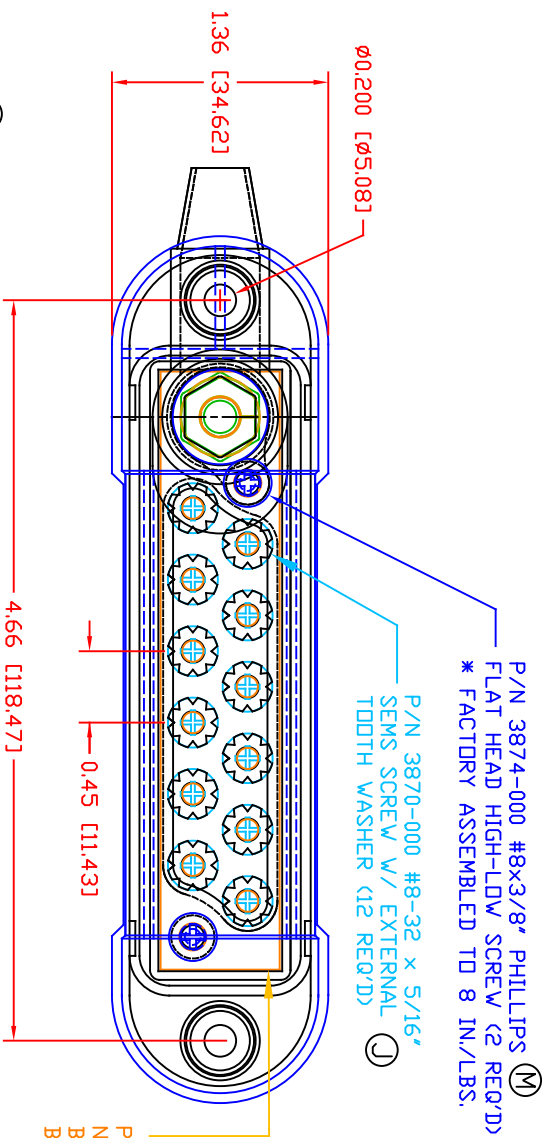

LTR	REVISIONS	DATE	INT.
A	3874-000 WAS 3872, 3873-001 WAS 3873	10-03-16	BRH
B	ADDED SUB ASSEMBLY P/N 73873-001	10-11-06	BRH
C	3842-001 ADDED 1 PLC, 3842-002 REMOVED 1 PLC	04-20-07	BRH
D	3842-003 WAS 3842-002	08-22-07	BRH
E	COVER 312N9P14 WAS 313N0V00	10-02-08	BRH
F	ADDED TORQUE SPECIFICATION	01-21-14	BRH
G	REMOVED SUB-ASSEMBLY NOTE P/N 73873	02-04-16	RAS
H	UPDATED TORQUE SPEC	08-09-16	MDL
I	3842-006 WAS 3842-003	03-24-17	JMM
J	3637-000 WAS 3637, 3870-000 WAS 3870	03-30-17	JMM
K	3842-B01 WAS 3842-001	06-14-17	JMM
L	ADDED FACTORY TORQUE SPEC TO 3874-000	5-23-24	RAS
M	REVISED TORQUE SPEC FROM 10 IN./LBS.	11-13-24	RAS

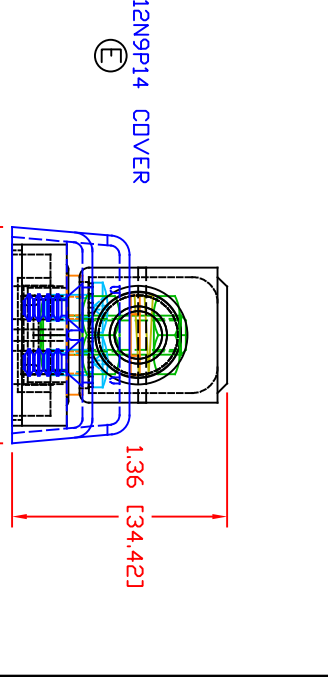
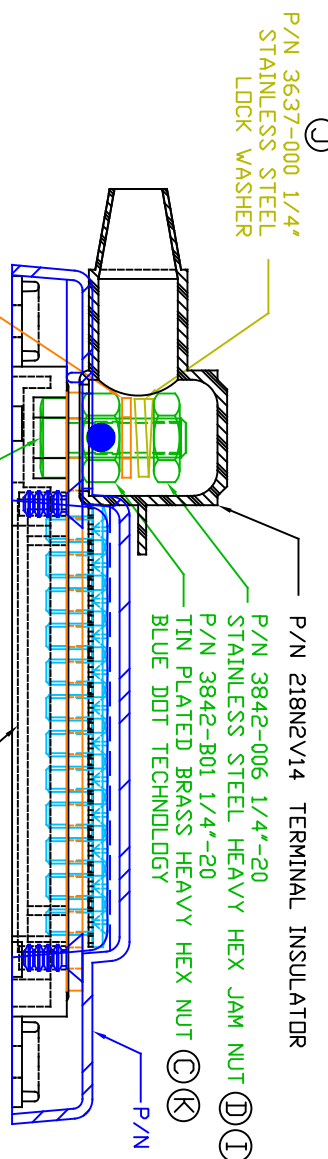

P/N 3637-000 1/4" STAINLESS STEEL LOCK WASHER  
 P/N 3644-001 1/4" I.D. x .500" O.D. STAINLESS STEEL FLAT WASHER  
 P/N 218N2V14 TERMINAL INSULATOR  
 P/N 3842-006 1/4"-20 STAINLESS STEEL HEAVY HEX JAM NUT  
 P/N 3842-B01 1/4"-20 TIN PLATED BRASS HEAVY HEX NUT  
 BLUE DDT TECHNOLOGY  
 P/N 312N9P14 COVER  
 P/N 31225N14 MOLDED BASE  
 P/N 3736-002 1/4"-20 x .750" STAINLESS STEEL HEX HEAD MACHINE SCREW

MATERIAL PART NO: 111210514UL  
 MATERIAL: GLASS FILLED NYLON  
 VENDOR PART NO: HYLON N2015 HL BK  
 SPECIFIC GRAVITY: 1.23  
 MELTING TEMP: 515 F [268 C]  
 UL RATING: UL 94 HB

INCLUDES P-1680811001 BLUE DDT MULTI LABEL, 1 PER CONTAINER  
 TESTED AT 240 AMPS @ 12VDC FOR 30 MINUTES, MAXIMUM  
 TEMPERATURE RISE WAS 7.8 DEG. C. MAXIMUM  
 TEMPERATURE RECORDED WAS 30.6 DEG. C.

SCALE FACTOR : NONE  
 ALL DIMENSIONS GIVEN AS: in [mm]  
 TOLERANCES UNLESS OTHERWISE SPECIFIED :  
 MOLDED PARTS: ±0.30" [±0.8mm]  
 HARDWARE ITEMS: ±.010" [±0.25mm]

**VTE Incorporated**  
 5437 Robinson Road, P.O. Box 790  
 Pellston, Michigan 49769  
 Telephone: 1-800-527-9256, 231-539-8000  
 FAX: 231-539-0914

REF.	DATE	DRN BY:	BRH	WEIGHT:
CUSTOMER DIMS	08-22-05	CHK'D BY:	BRH	
TITLE:	12-POINT TERMINAL STRIP		SCALE:	
MATERIAL:	GLASS-FILLED NYLON		PART NO:	71225N14
COLOR:	BLACK	DRG CLASS	REV M	