

THE INFORMATION CONTAINED IN THIS DRAWING IS THE SOLE PROPERTY OF VTE INCORPORATED. ANY REPRODUCTION IN PART OR WHOLE WITHOUT THE WRITTEN PERMISSION OF VTE INCORPORATED IS PROHIBITED. VTE MAKES NO WARRANTY, EXPRESSED OR IMPLIED, AS TO THE SUITABILITY OF A PRODUCT FOR ANY INTENDED USE. THE CUSTOMER SHALL BEAR THE SOLE RESPONSIBILITY OF DETERMINING THE SUITABILITY OF ANY VTE PRODUCT FOR ITS END USE.

P/N 3874-000 #8 x 3/8 PHILLIPS FLAT HEAD HIGH-LOW SCREW STAINLESS STEEL (2 PLCS)
 * FACTORY ASSEMBLED TO 8 IN./LBS.

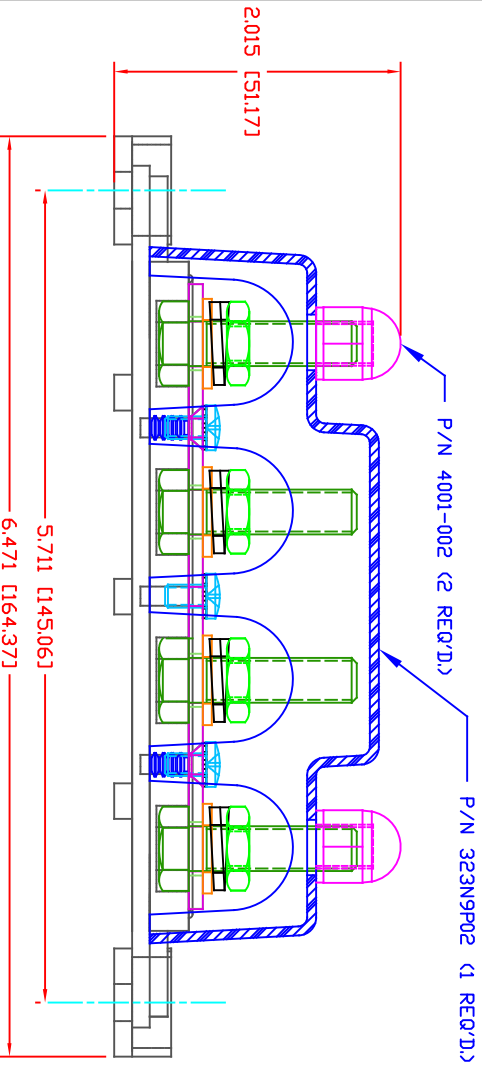
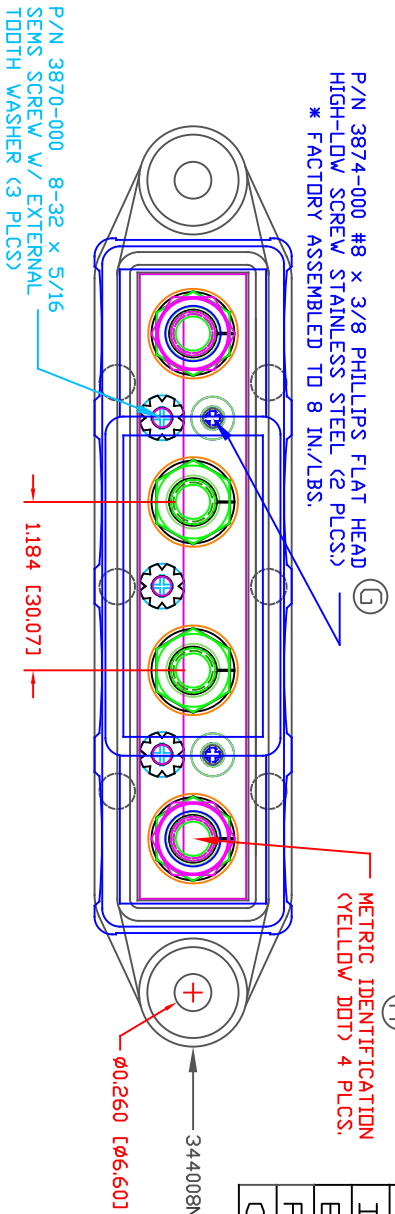

LTR	REVISIONS	DATE	INT.
A	ADDED METRIC IDENTIFICATION METHOD	04-05-11	BRH
B	REMOVED BLUE DOT INSTRUCTION	10-21-15	RAS
C	UPDATED DIMENSIONS AND DESCRIPTIONS	02-02-16	RAS
D	UPDATED CURRENT RATING	06-02-16	RAS
E	UPDATED MAXIMUM AMPERAGE RATING	1-30-17	RAS
F	ADDED FACTORY TORQUE SPEC TO 3874-000	5-23-24	RAS
G	REVISED TORQUE SPEC FROM 10 IN./LBS.	11-13-24	RAS

MATERIAL PART NO: 7111210502
 MATERIAL: GLASS FILLED NYLON
 VENDOR PART NO: HYLON N2015 HL NAT
 SPECIFIC GRAVITY: 1.23
 MELTING TEMP: 515 F [268 C]
 UL RATING: UL 94 HB

INCLUDES COVER P/N 723 AND ASSEMBLY P/N 74008N0
 MAXIMUM RECOMMENDED FASTENER TORQUE: (144 IN./LBS.) [16.2 Nm]
 (ANTI-SEIZE RECOMMENDED)

MAXIMUM RECOMMENDED AMPERAGE: 250 AMPS @ 12VDC

SCALE FACTOR: NONE
 ALL DIMENSIONS GIVEN AS: in [mm]
 TOLERANCES UNLESS OTHERWISE SPECIFIED:
 MOLDED PARTS: ±0.30" [±0.8mm]
 HARDWARE ITEMS: ±.010" [±0.25mm]

VTE Incorporated
 5437 Robinson Road, P.O. Box 790
 Pellston, Michigan 49769
 Telephone: 1-800-527-9256, 231-539-8000
 FAX: 231-539-0914

REF.	DATE	DRN BY:	BRH	WEIGHT:
CUSTOMER DIMS	08-16-10	CHK'D BY:	BRH	.458LBS [207.80G]
TITLE:	BUSBAR, 4 POINT, M8 W/ COVERED		SCALE:	NONE
MATERIAL:	GLASS-FILLED NYLON	PART NO:	74008N1N02	
COLOR:	RED	DRG CLASS	REV G	