

THE INFORMATION CONTAINED IN THIS DRAWING IS THE SOLE PROPERTY OF VTE INCORPORATED. ANY REPRODUCTION IN PART OR WHOLE WITHOUT THE WRITTEN PERMISSION OF VTE INCORPORATED IS PROHIBITED. VTE MAKES NO WARRANTY, EXPRESSED OR IMPLIED, AS TO THE SUITABILITY OF A PRODUCT FOR ANY INTENDED USE. THE CUSTOMER SHALL BEAR THE SOLE RESPONSIBILITY OF DETERMINING THE SUITABILITY OF ANY VTE PRODUCT FOR ITS END USE.

LTR.	REVISIONS	DATE	INT.
A	REMOVED BLUE DOT INSTRUCTION	21OCT15	RAS
B	REPLACED P/N 3843-002 WITH P/N 3843-008	28MAR16	RAS
C	UPDATED CURRENT RATING	02JUN16	RAS
D	UPDATED MAXIMUM AMPERAGE RATING	30JAN17	RAS

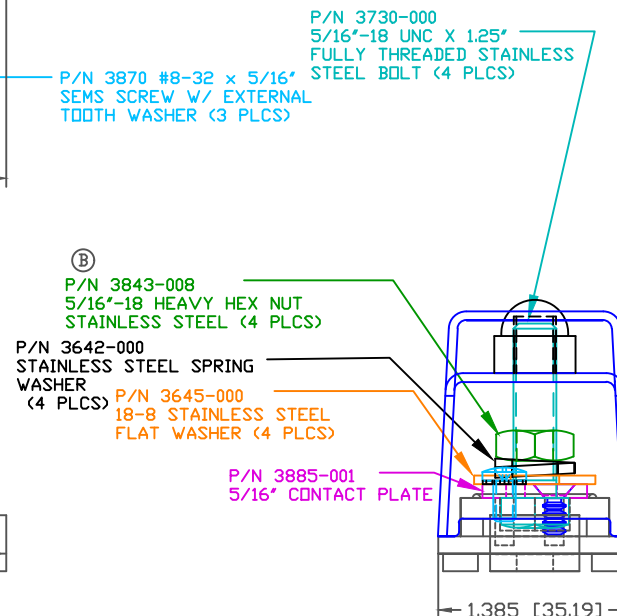
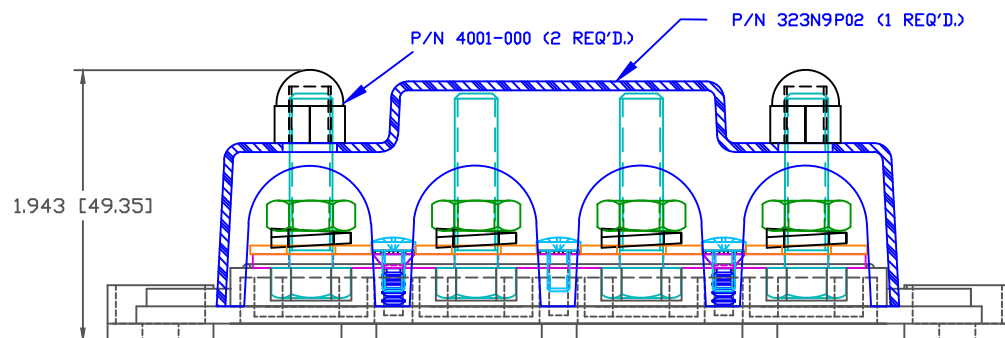
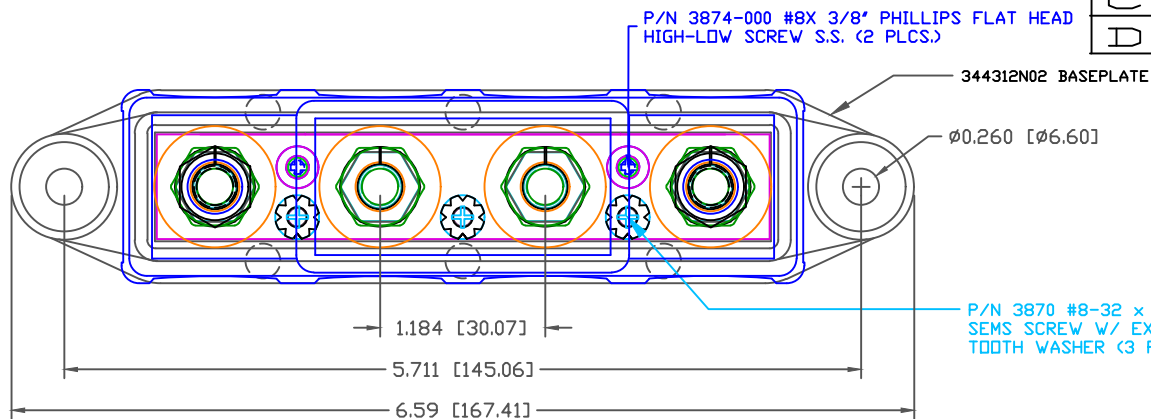

SCALE FACTOR : NONE
 ALL DIMENSIONS GIVEN AS: in [mm]
 TOLERANCES UNLESS OTHERWISE SPECIFIED :
 MOLDED PARTS: ±.030" [±0.8mm]
 HARDWARE ITEMS: ±.010" [±0.25mm]

MATERIAL PART NO:
 MATERIAL:
 VENDOR PART NO:
 SPECIFIC GRAVITY:
 MELTING TEMP:
 U.L. RATING:

7111210502
 GLASS FILLED NYLON
 NYLON N2015 HL NAT
 1.23
 515 F [268 C]
 UL 94 HB

INCLUDES COVER P/N 723N1 AND ASSEMBLY 74312N0N02
 MAXIMUM RECOMMENDED FASTENER TORQUE: 12 FT./LBS. (144 IN./LBS.)
 (ANTI-SEIZE RECOMMENDED)
 MAXIMUM RECOMMENDED AMPERAGE: 250 AMPS @ 12VDC



VTE Incorporated
 5437 Robinson Road, P.O. Box 790
 Pellston, Michigan 49769
 Telephone: 1-800-527-9256, 231-539-8000
 FAX: 231-539-0914

REF:	DATE:	DRN BY:	BRH	WEIGHT:
CUSTOMER DIMS	08-16-10	CHK'D BY:	BRH	
TITLE: BUSBAR, 4 POINT, 5/16" W/ COVER, RED			SCALE: NONE	
MATERIAL: GLASS-FILLED NYLON		PART NO.		
COLOR: RED		DRG CLASS REV D		74312N1N02