

THE INFORMATION CONTAINED IN THIS DRAWING IS THE SOLE PROPERTY OF VTE INCORPORATED. ANY REPRODUCTION IN PART OR WHOLE WITHOUT THE WRITTEN PERMISSION OF VTE INCORPORATED IS PROHIBITED. VTE MAKES NO WARRANTY, EXPRESSED OR IMPLIED, AS TO THE SUITABILITY OF A PRODUCT FOR ANY INTENDED USE. THE CUSTOMER SHALL BEAR THE SOLE RESPONSIBILITY OF DETERMINING THE SUITABILITY OF ANY VTE PRODUCT FOR ITS END USE.

LTR.	REVISIONS	DATE	INT.
A	REMOVED BLUE DOT INSTRUCTION	10-21-15	RAS
B	REPLACED P/N 3844-002 WITH P/N 3844-009	03-18-16	RAS
C	UPDATED CURRENT RATING	06-02-16	RAS
D	UPDATED MAXIMUM AMPERAGE RATING	30JAN17	RAS

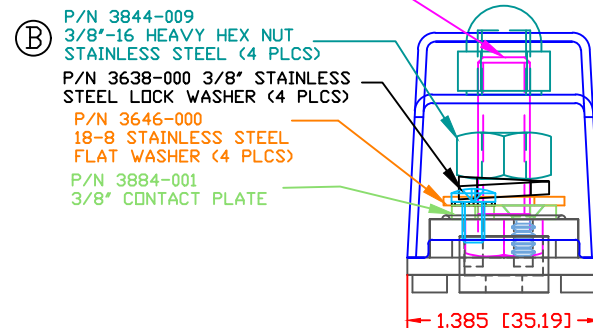
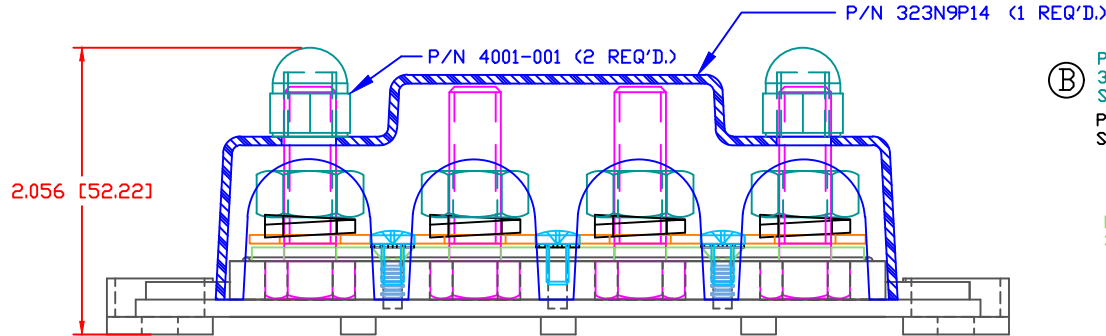
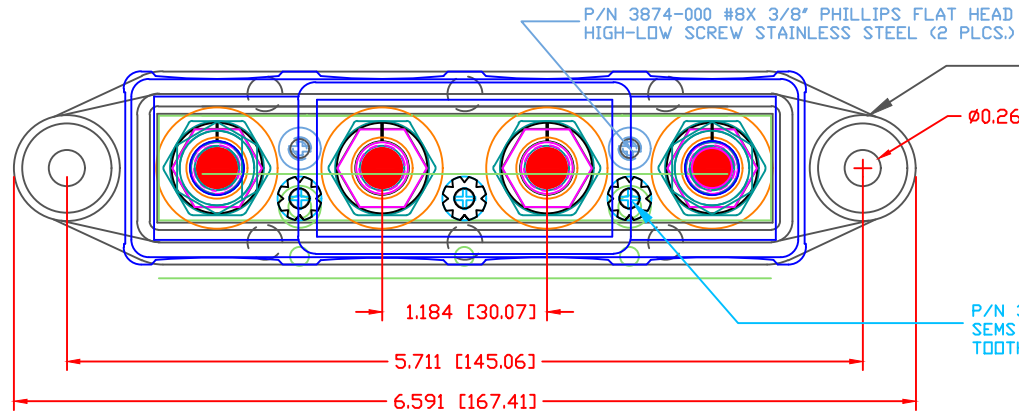

SCALE FACTOR : NONE
 ALL DIMENSIONS GIVEN AS: in [mm]
 TOLERANCES UNLESS OTHERWISE SPECIFIED :
 MOLDED PARTS: ±0.30" [±0.8mm]
 HARDWARE ITEMS: ±0.10" [±0.25mm]

MATERIAL PART NO: 111210514UL
 MATERIAL: GLASS FILLED NYLON
 VENDOR PART NO: HYLON N2015 HL BK
 SPECIFIC GRAVITY: 1.23
 MELTING TEMP: 515 F [268 C]
 U.L. RATING: UL 94 HB

INCLUDES COVER P/N 723N6 AND ASSEMBLY P/N 74375N0N14
 MAXIMUM RECOMMENDED FASTENER TORQUE: 15 FT./LBS. (180 IN./LBS.)
 (ANTI-SEIZE RECOMMENDED)

MAXIMUM RECOMMENDED AMPERAGE: 250 AMPS @ 12VDC



VTE Incorporated
 5437 Robinson Road, P.O. Box 790
 Pellston, Michigan 49769
 Telephone: 1-800-527-9256, 231-539-8000
 FAX: 231-539-0914

REF:	DATE:	DRN BY:	BRH	WEIGHT:
CUSTOMER DIMS	08-16-10	CHK'D BY:	BRH	.558LBS [253.30G]
TITLE: BUSBAR, 4 POINT, 3/8" W/ COVER				SCALE: NONE
MATERIAL: GLASS-FILLED NYLON			PART NO.	
COLOR: BLACK			74375N1N14	
DRG CLASS		REV D		