

THE INFORMATION CONTAINED IN THIS DRAWING IS THE SOLE PROPERTY OF VTE INCORPORATED. ANY REPRODUCTION IN PART OR WHOLE WITHOUT THE WRITTEN PERMISSION OF VTE INCORPORATED IS PROHIBITED. VTE MAKES NO WARRANTY, EXPRESSED OR IMPLIED, AS TO THE SUITABILITY OF A PRODUCT FOR ANY INTENDED USE. THE CUSTOMER SHALL BEAR THE SOLE RESPONSIBILITY OF DETERMINING THE SUITABILITY OF ANY VTE PRODUCT FOR ITS END USE.

LTR.	REVISIONS	DATE	INT.
A	REPLACED P/N 3843-002 WITH P/N 3843-008	03-28-16	RAS
B	REPLACED P/N 3842-002 WITH P/N 3842-005	03-28-16	RAS
C	REPLACED P/N 3843-000 WITH P/N 3843-B00	06-05-17	JMM
D	REPLACED P/N 3842-001 WITH P/N 3842-B01	06-14-17	JMM

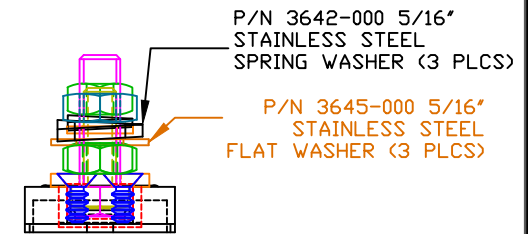
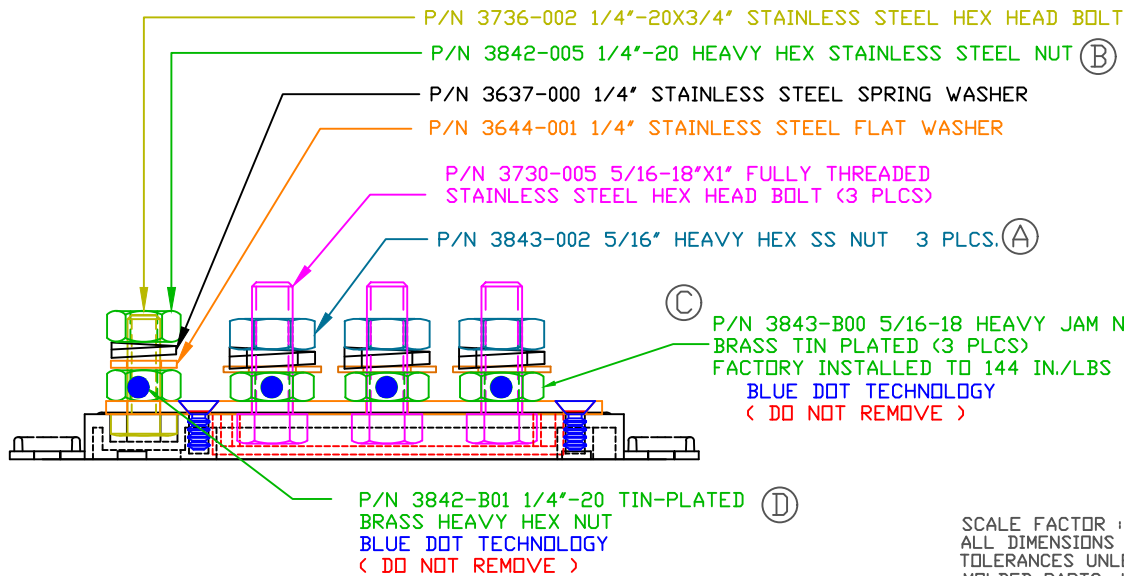
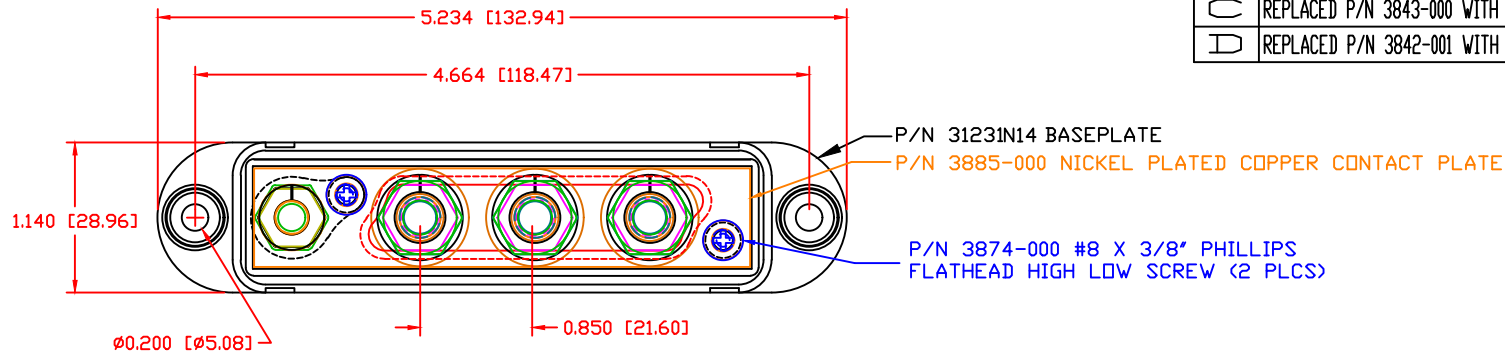

SCALE FACTOR : NONE
ALL DIMENSIONS GIVEN AS: in [mm]
TOLERANCES UNLESS OTHERWISE SPECIFIED :
MOLDED PARTS: ±.030" [±0.8mm]
HARDWARE ITEMS: ±.010" [±0.25mm]

MATERIAL PART NO: 111210514UL
MATERIAL: GLASS FILLED NYLON
VENDOR PART NO: HYLON N2015 HL BK
SPECIFIC GRAVITY: 1.23
MELTING TEMP: 515 F [268 C]
U.L. RATING: UL 94 HB

TORQUE:
1/4" NUT - MAXIMUM RECOMMENDED TORQUE: 60 IN./LBS.
5/16" NUT - MAXIMUM RECOMMENDED TORQUE: 144 IN./LBS.
(ANTI-SEIZE RECOMMENDED)

INCLUDES P-16808110001 BLUE DOT MULTI LABEL, 1 PER CONTAINER
MAXIMUM AMPERAGE: 210 AMPS @12VDC



VTE Incorporated
5437 Robinson Road, P.O. Box 790
Pellston, Michigan 49769
Telephone: 1-800-527-9256, 231-539-8000
FAX: 231-539-0914

REF:	DATE:	DRN BY:	BRH	WEIGHT:
CUSTOMER DIMS	03-02-10	CHK'D BY:	BRH	
TITLE:			SCALE:	
5/16" 4-POINT CONTACT PLATE				
MATERIAL:		PART NO.		
COLOR: BLACK		7705X0N14		
DRG CLASS		REV D		