

THE INFORMATION CONTAINED IN THIS DRAWING IS THE SOLE PROPERTY OF VTE INCORPORATED. ANY REPRODUCTION IN PART OR WHOLE WITHOUT THE WRITTEN PERMISSION OF VTE INCORPORATED IS PROHIBITED. VTE MAKES NO WARRANTY, EXPRESSED OR IMPLIED, AS TO THE SUITABILITY OF A PRODUCT FOR ANY INTENDED USE. THE CUSTOMER SHALL BEAR THE SOLE RESPONSIBILITY OF DETERMINING THE SUITABILITY OF ANY VTE PRODUCT FOR ITS END USE.

LTR.	REVISIONS	DATE	INT.
A	UPDATED TORQUE VALUE	07-01-20	EJE
B	UPDATED TORQUE VALUE FROM 56 IN/LBS	05-24-20	EJE

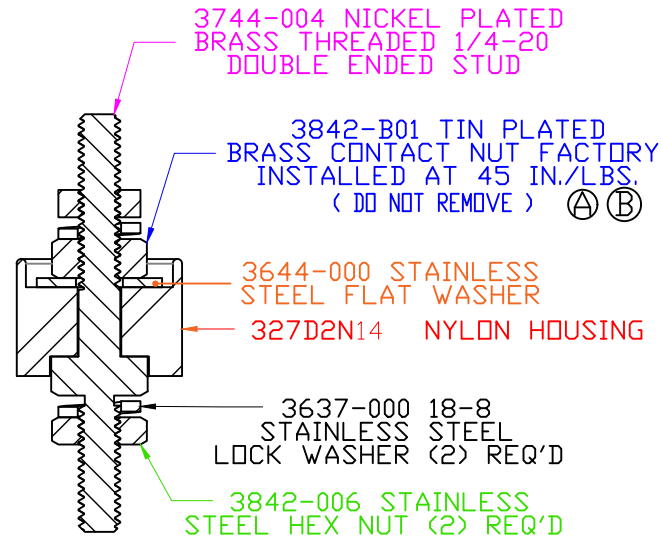
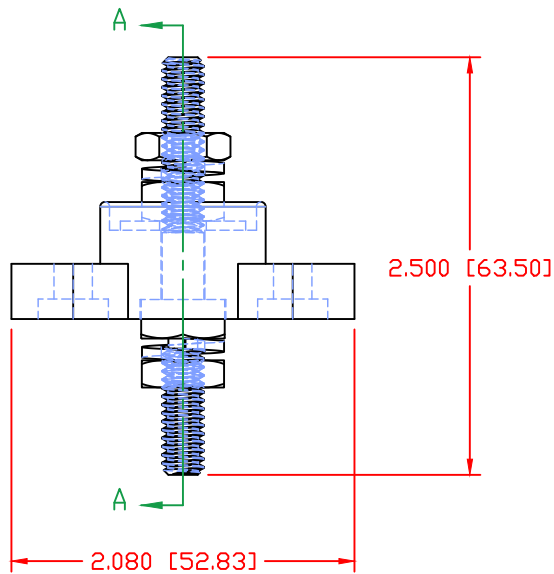
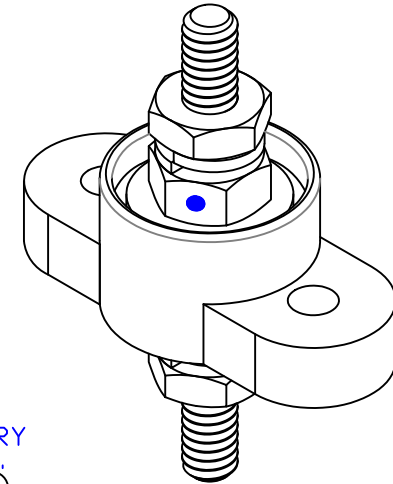
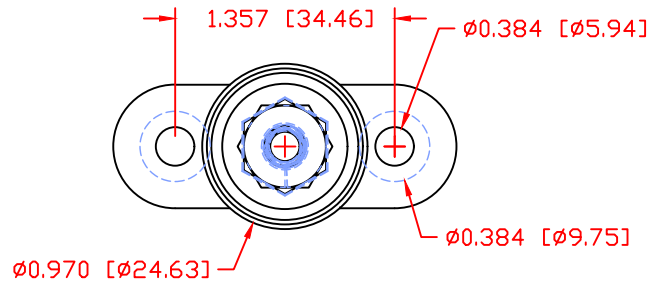

SECTION A-A

SCALE FACTOR : NONE
 ALL DIMENSIONS GIVEN AS: in [mm]
 TOLERANCES UNLESS OTHERWISE SPECIFIED :
 MOLDED PARTS: ±.030" [±0.8mm]
 HARDWARE ITEMS: ±.010" [±0.25mm]

MATERIAL PART NO: 1111210514UL
 MATERIAL: GLASS FILLED NYLON
 VENDOR PART NO: NYLON N2015 HL BK
 SPECIFIC GRAVITY: 1.23
 MELTING TEMP: 515 F [268 C]
 U.L. RATING: UL 94 HB

MAXIMUM RECOMMENDED FASTENER TORQUE: 45 IN./LBS.
 A B

VTE Incorporated
 5437 Robinson Road, P.O. Box 790
 Pellston, Michigan 49769
 Telephone: 1-800-527-9256, 231-539-8000
 FAX: 231-539-0914

REF:	DATE: 5-22-19	DRN BY: RAS	WEIGHT:
		CHK'D BY: PJK	
TITLE: 1/4"-20 JUNCTION BLOCK, STUD TYPE, PASS-THRU			
MATERIAL: GLASS FILLED NYLON		PART NO.	
COLOR: BLACK	DRG CLASS	REV B	77225N14