

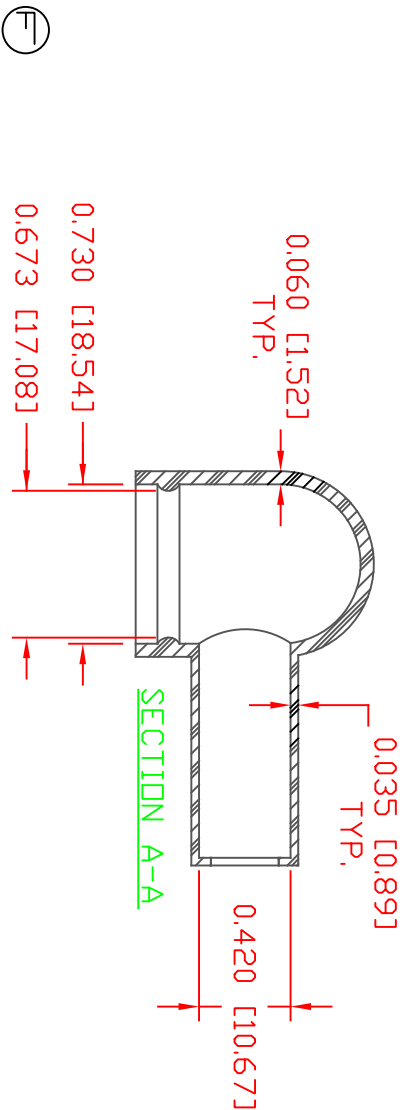

THE INFORMATION CONTAINED IN THIS DRAWING IS THE SOLE PROPERTY OF VTE INCORPORATED. ANY REPRODUCTION IN PART OR WHOLE WITHOUT THE WRITTEN PERMISSION OF VTE INCORPORATED IS PROHIBITED. VTE MAKES NO WARRANTY, EXPRESSED OR IMPLIED, AS TO THE SUITABILITY OF A PRODUCT FOR ANY INTENDED USE. THE CUSTOMER SHALL BEAR THE SOLE RESPONSIBILITY OF DETERMINING THE SUITABILITY OF ANY VTE PRODUCT FOR ITS END USE.

LR.	REVISIONS	DATE	INT.
A	MATERIAL NOTES REVISED	5-07-02	JC
B	REVISED TO AGREE WITH PARTS AS MFG.	4-04-03	JC
C	UPDATED DIMENSION	10-11-16	RAS
D	UPDATED DIMS TO IN (MM)	02-27-17	JMM
E	ADDED (REFERENCE ONLY) TO OVERALL LENGTH DIMENSION	12-18-17	RAS
F	UPDATED MATERIAL INFORMATION	8-02-22	RAS

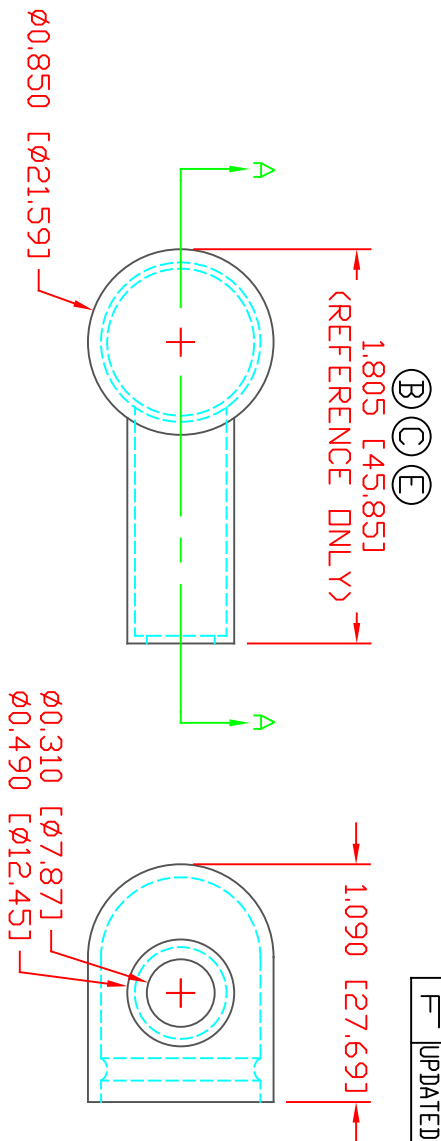

MATERIAL PART NO: 1101700109
 MATERIAL: BLUE PVC
 VENDOR PART NO: 7844-70 BLUE 1812
 SPECIFIC GRAVITY: 1.36
 HARDNESS 10 SEC: A
 HARDNESS SCALE: 1100
 TENSILE STRENGTH, PSI: 310
 ELONGATION, %: 200
 TEAR STRENGTH, PPI: HB
 FLAME CLASS UL: 320-340 [160-171]
 MELT TEMP., DEGREES F [C]: N/A
 DIELECTRIC STRENGTH, V./MIL:

SCALE FACTOR : NONE
 ALL DIMENSIONS GIVEN AS: In, (mm)
 TOLERANCES UNLESS OTHERWISE SPECIFIED :
 MOLDED PARTS: ±.030" (±0.8mm)
 ALL ANGLES ARE ± 1 DEGREE



VTE Incorporated
 5437 Robinson Road, P.O. Box 790
 Pellston, Michigan 49769
 Telephone: 1-800-527-9256, 231-539-8000
 FAX: 231-539-0914

REF:	DATE:	DRN BY:	JC	WEIGHT:
CUSTOMER DIMS	4-8-98	CHK'D BY:		011 LBS. / 4.98 G.
TITLE:	ALTERNATOR BOOT			
MATERIAL:	PVC	PART NO:	800N8V09	
COLOR:	BLUE	DRG CLASS	REV F	