

THE INFORMATION CONTAINED IN THIS DRAWING IS THE SOLE PROPERTY OF VTE INCORPORATED. ANY REPRODUCTION IN PART OR WHOLE WITHOUT THE WRITTEN PERMISSION OF VTE INCORPORATED IS PROHIBITED. VTE MAKES NO WARRANTY, EXPRESSED OR IMPLIED, AS TO THE SUITABILITY OF A PRODUCT FOR ANY INTENDED USE. THE CUSTOMER SHALL BEAR THE SOLE RESPONSIBILITY OF DETERMINING THE SUITABILITY OF ANY VTE PRODUCT FOR ITS END USE.

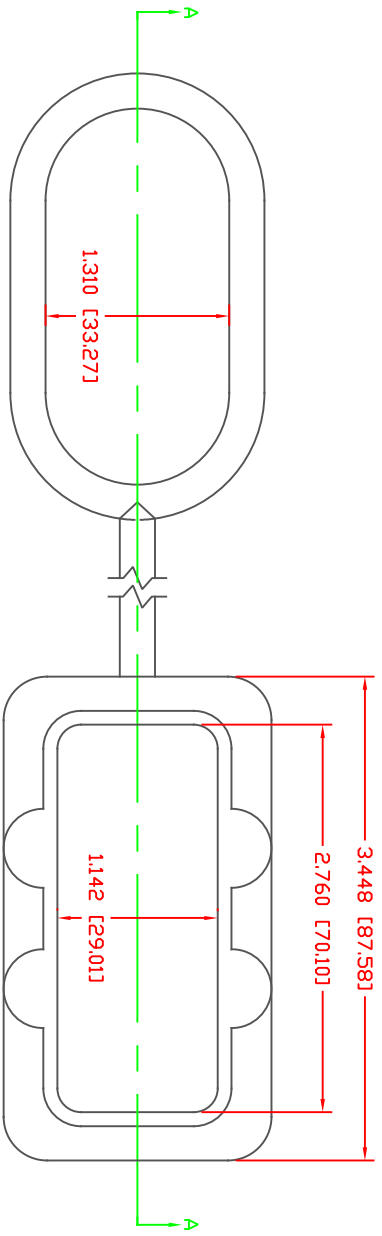

LTR.	REVISIONS	DATE	INT.
A	REDRAWN TO AGREE WITH PARTS AS MFG'D	12-26-12	JC
B	SLIGHTLY TEXTURED COSMETIC SURFACE ADDED	8-07-17	RAS
C	UPDATED LENGTH DIMENSION AS REFERENCE ONLY	1-05-18	RAS
D	UPDATED LENGTH DIMENSION FROM 1.440 [36.58]	9-25-18	RAS
E	UPDATED MATERIAL INFORMATION	8-02-22	RAS

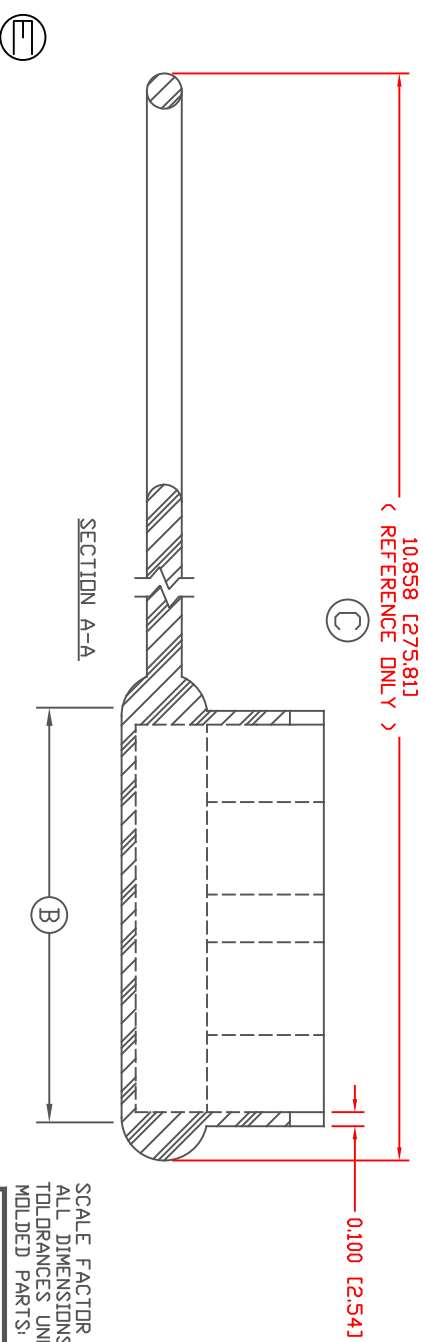
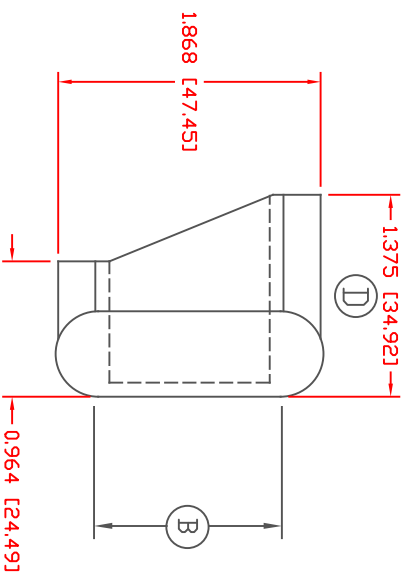

MATERIAL PART NO: 1101700109
 MATERIAL: BLUE PVC
 VENDOR PART NO: 7844-70
 SPECIFIC GRAVITY: BLUE 1812
 HARDNESS 10 SEC: 136
 HARDNESS SCALE: A
 TENSILE STRENGTH, PSI: 1100
 ELONGATION, %: 310
 TEAR STRENGTH, PPI: 200
 FLAME CLASS UL: HB
 MELT TEMP., DEGREES F [C]: 320-340 [160-171]
 DIELECTRIC STRENGTH, V./MIL: N/A

SCALE FACTOR : NONE
 ALL DIMENSIONS GIVEN AS: in [mm]
 TOLERANCES UNLESS OTHERWISE SPECIFIED :
 MOLDED PARTS: ±.030" [±0.8mm]

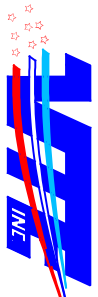

VTE Incorporated
 5437 Robinson Road, P.O. Box 790
 Pellston, Michigan 49769
 Telephone: 1-800-527-9256, 231-539-8000
 FAX: 231-539-0914

REF:	DATE:	DRN BY:	JC	WEIGHT:
	4-13-98	CHK'D BY:		16 LBS. / 70.9 G.
TITLE: ANDERSON/SME BATTERY CHARGER CONNECTOR COVER				
MATERIAL: PVC		PART NO: 832N0V09		
COLOR: BLUE		DRG CLASS: REV E		

DD NOT SCALE