

THE INFORMATION CONTAINED IN THIS DRAWING IS THE SOLE PROPERTY OF VTE INCORPORATED. ANY REPRODUCTION IN PART OR WHOLE WITHOUT THE WRITTEN PERMISSION OF VTE INCORPORATED IS PROHIBITED. VTE MAKES NO WARRANTY, EXPRESSED OR IMPLIED, AS TO THE SUITABILITY OF A PRODUCT FOR ANY INTENDED USE. THE CUSTOMER SHALL BEAR THE SOLE RESPONSIBILITY OF DETERMINING THE SUITABILITY OF ANY VTE PRODUCT FOR ITS END USE.

| LR. | REVISIONS | DATE | INT. |
|-----|---|----------|------|
| A | REDRAWN AND UPDATED | 9-15-17 | RAS |
| B | UPDATED DIMENSIONS AND ADDED REFERENCE ONLY | 11-21-18 | RAS |
| C | UPDATED DIMENSION FROM 2.587 [65.711] | 11-21-18 | RAS |
| D | UPDATED DIMENSIONS FROM 1.530 [38.861] | 11-21-18 | RAS |
| E | UPDATED MATERIAL INFORMATION | 8-02-22 | RAS |

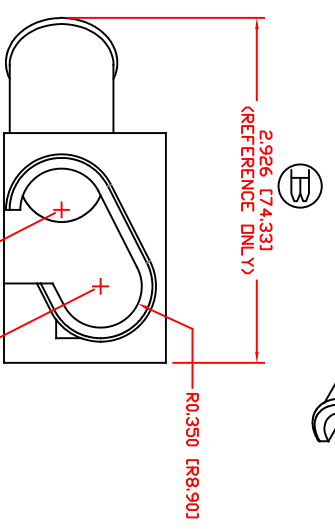
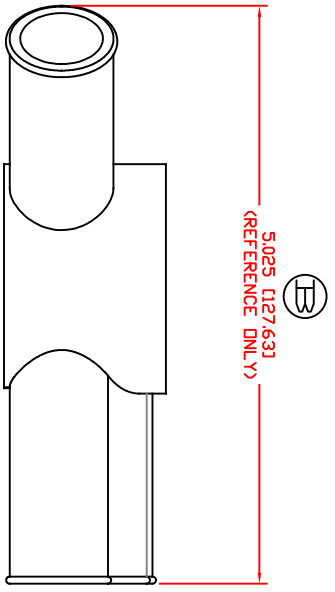
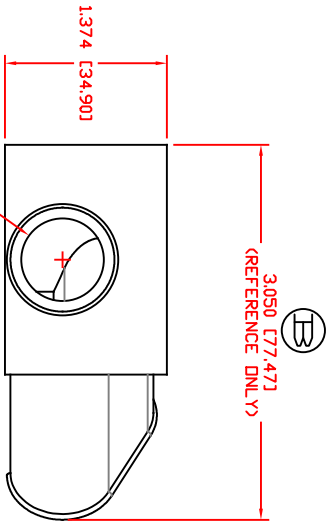
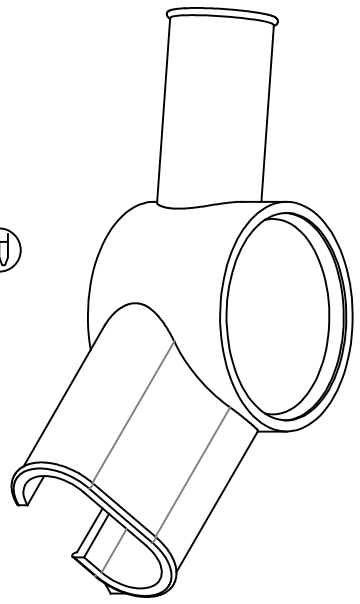
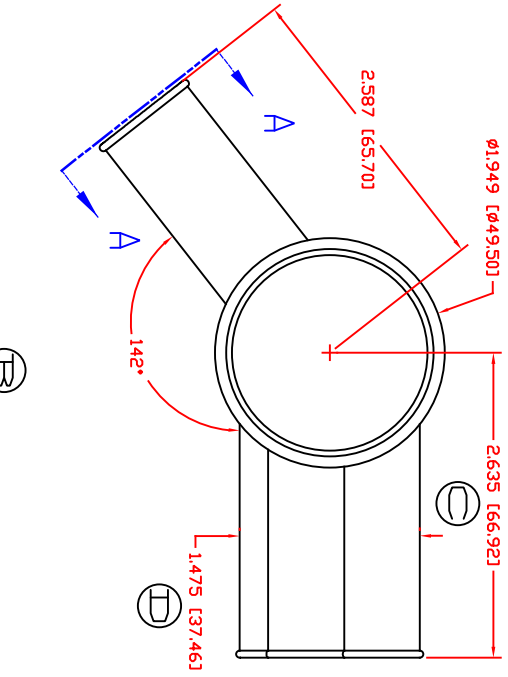

VIEW A-A
52.00°

⊖ TYPICAL WALL THICKNESS .080 [2.03]

MATERIAL PART NO: 1101700109
 MATERIAL: BLUE PVC
 VENDOR PART NO: 7844-70 BLUE 1812
 SPECIFIC GRAVITY: 1.36
 HARDNESS 10 SEC: 70
 HARDNESS SCALE: A
 TENSILE STRENGTH, PSI: 1100
 ELONGATION, %: 310
 TEAR STRENGTH, PPI: 200
 FLAME CLASS UL: HB
 MELT TEMP, DEGREES F [C]: 320-340 [160-171]
 DIELECTRIC STRENGTH, V./MIL: N/A

SCALE FACTOR : NONE
 ALL DIMENSIONS GIVEN AS IN [mm]
 TOLERANCES UNLESS OTHERWISE SPECIFIED :
 MOLDED PARTS: ±.030" [±0.8mm]

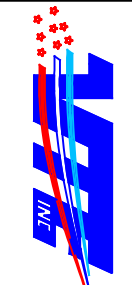

VTE Incorporated
 5437 Robinson Road, P.O. Box 790
 Pellston, Michigan 49769
 Telephone: 1-800-527-9256, 231-539-8000
 FAX: 231-539-0914

| | | | | |
|---------------------------|---------|-------------------|-------|--------------------|
| REF: | DATE: | DRN BY: | RAS | WEIGHT: |
| CUSTOMER DIMS | 9-15-17 | CHK'D BY: | PAK | 073 LBS. / 32.9 G. |
| TITLE: BATTERY CABLE BOOT | | | | |
| MATERIAL: | PVC | PART NO: 955N9V09 | | |
| COLOR: | BLUE | DRG CLASS | REV E | |