

THE INFORMATION CONTAINED IN THIS DRAWING IS THE SOLE PROPERTY OF VTE INCORPORATED. ANY REPRODUCTION IN PART OR WHOLE WITHOUT THE WRITTEN PERMISSION OF VTE INCORPORATED IS PROHIBITED. VTE MAKES NO WARRANTY, EXPRESSED OR IMPLIED, AS TO THE SUITABILITY OF A PRODUCT FOR ANY INTENDED USE. THE CUSTOMER SHALL BEAR THE SOLE RESPONSIBILITY OF DETERMINING THE SUITABILITY OF ANY VTE PRODUCT FOR ITS END USE.

LTR.	REVISIONS	DATE	INT.
A	PN 331NOV** CHANGED TO 331NON**	08-08-16	MDL
B	REPLACED P/N 3843-001 WITH P/N 3843-009	16JAN17	RAS

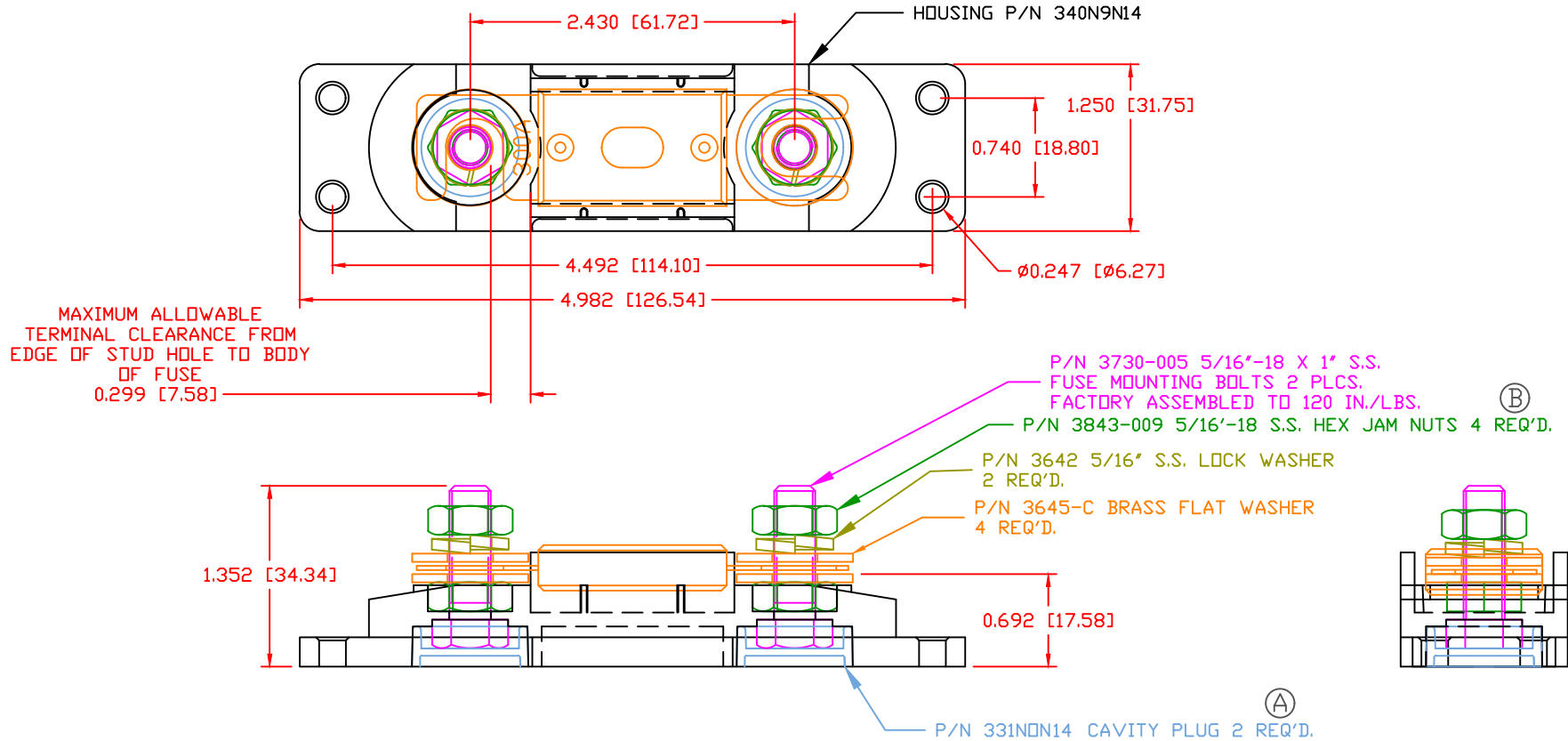

SCALE FACTOR : NONE
 ALL DIMENSIONS GIVEN AS: in [mm]
 TOLERANCES UNLESS OTHERWISE SPECIFIED :
 MOLDED PARTS: ±0.30" [±0.8mm]
 HARDWARE ITEMS: ±0.10" [±0.25mm]

FUSE NOT INCLUDED

MATERIAL PART NO:
 MATERIAL:
 VENDOR PART NO:
 SPECIFIC GRAVITY:
 MELTING TEMP:
 U.L. RATING:

1111210514UL
 GLASS FILLED NYLON
 HYLON N2015 HL BK
 1.23
 515 F [268 C]
 UL 94 HB

MAXIMUM RECOMMENDED AMPERAGE: 300 AMPS @ 12 VDC



VTE Incorporated
 5437 Robinson Road, P.O. Box 790
 Pellston, Michigan 49769
 Telephone: 1-800-527-9256, 231-539-8000
 FAX: 231-539-0914

REF: REPLACES ANB740N7P14	DATE: 7-13-15	DRN BY: BRH	WEIGHT:
TITLE: ANL TYPE FUSE HOLDER W/O INSULATORS OR COVER		CHK'D BY: BRH	SCALE:
MATERIAL:		PART NO.	
COLOR: BLACK	DRG CLASS REV B	ANB740X1N14	