

THE INFORMATION CONTAINED IN THIS DRAWING IS THE SOLE PROPERTY OF VTE INCORPORATED. ANY REPRODUCTION IN PART OR WHOLE WITHOUT THE WRITTEN PERMISSION OF VTE INCORPORATED IS PROHIBITED. VTE MAKES NO WARRANTY, EXPRESSED OR IMPLIED, AS TO THE SUITABILITY OF A PRODUCT FOR ANY INTENDED USE. THE CUSTOMER SHALL BEAR THE SOLE RESPONSIBILITY OF DETERMINING THE SUITABILITY OF ANY VTE PRODUCT FOR ITS END USE.

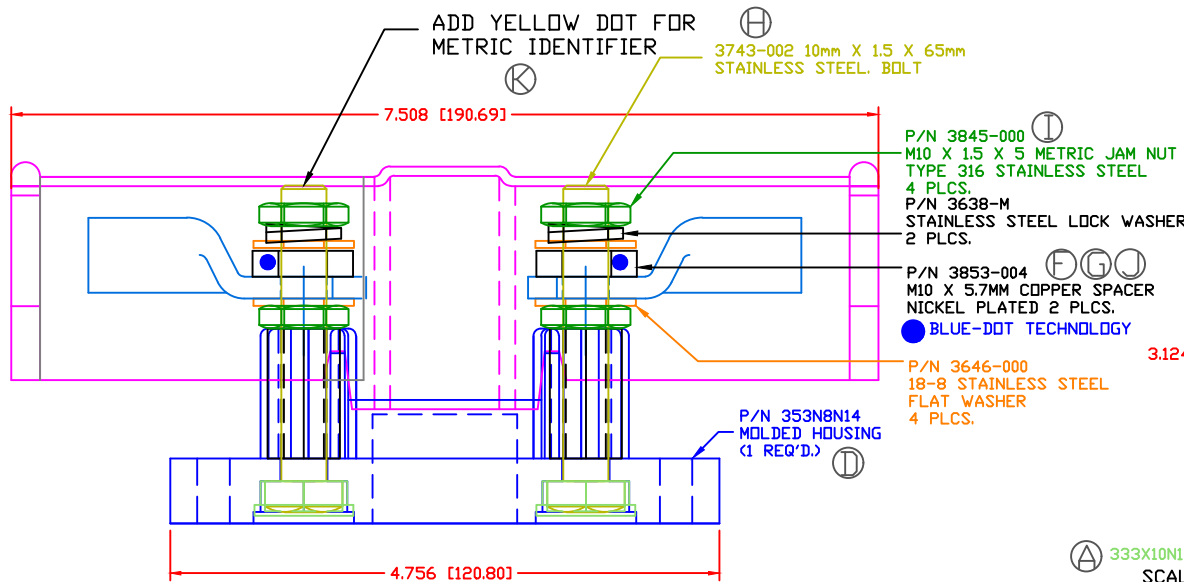

LTR.	REVISIONS	DATE	INT.
A	3743-003 WAS 3743-002, 333X10N** WAS 333X10N**	7-10-07	BRH
B	3638-M WAS 3642-000, 3646-000 WAS 3645-000 ADDED CALLOUT FOR 3743-003	12-15-09	BRH
C	751N9V00 WAS 351N9V00	4-23-13	BRH
D	353N8N** WAS 353N9N**	9-17-13	BRH
E	751N9P00 WAS 751N9V00	7-30-15	BRH
F	3853-004 WAS 3853-212	08-02-16	RAS
G	3853-212 WAS 3853-004	11-04-16	JMM
H	3743-002 WAS 3743-003	12-01-16	RAS
I	INCREASED QTY OF PART # 3845-000 FROM 2 TO 4	12-06-16	RAS
J	REPLACED P/N 3853-212 WITH P/N 3853-004	1-16-17	RAS
K	ADDED YELLOW DOT IDENTIFIER FOR METRIC	12-14-17	RAS
L	ADDED RECOMMENDED TORQUE VALUE	1-08-18	RAS

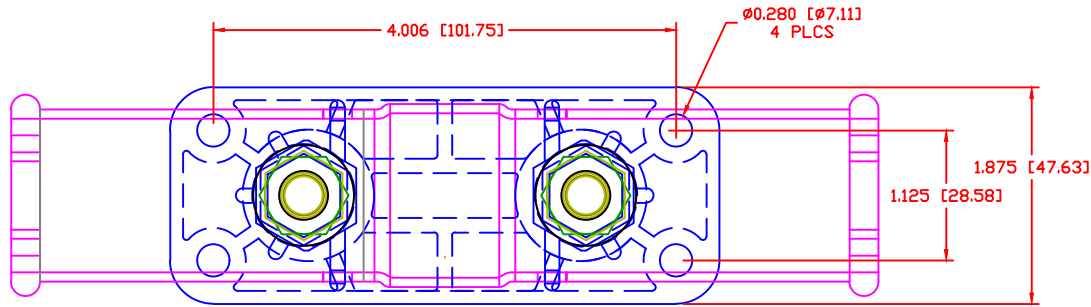
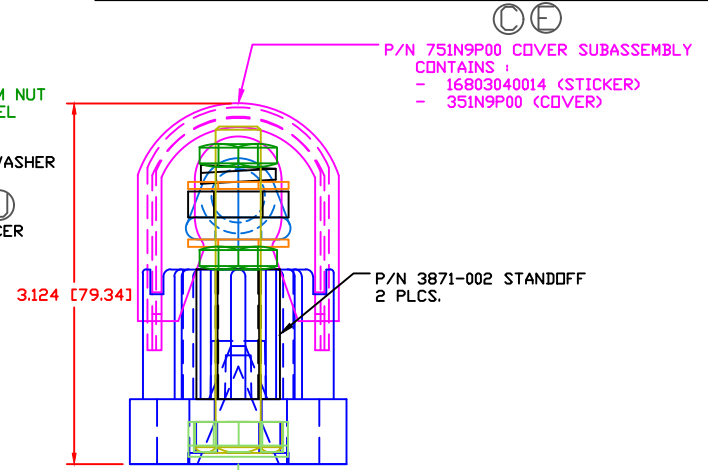

SCALE FACTOR : NONE  
 ALL DIMENSIONS GIVEN AS: in [mm]  
 TOLERANCES UNLESS OTHERWISE SPECIFIED :  
 MOLDED PARTS: ±.030" [±0.8mm]  
 HARDWARE ITEMS: ±.010" [±0.25mm]

INCLUDES P-16808110001 BLUE DOT MULTI LABEL, 1 PER CONTAINER  
 FUSE AND LUG TERMINALS ARE NOT INCLUDED, (SHOWN FOR REFERENCE ONLY)

MATERIAL PART NO:  
 MATERIAL:  
 VENDOR PART NO:  
 SPECIFIC GRAVITY:  
 MELTING TEMP:  
 U.L. RATING:

111210514UL  
 GLASS FILLED NYLON  
 NYLON N2015 HL BK  
 1.23  
 515 F [268 C]  
 UL 94 HB

COVER MATERIAL:

CLEAR POLYPROPYLENE

TORQUE: M10 X 1.5 NUT MAXIMUM RECOMMENDED TORQUE: 180 IN./LBS.  
 ( 20.33 Nm )



VTE Incorporated  
 5437 Robinson Road, P.O. Box 790  
 Pellston, Michigan 49769  
 Telephone: 1-800-527-9256, 231-539-8000  
 FAX: 231-539-0914

REF:	DATE:	DRN BY:	BRH	WEIGHT:
CUSTOMER DIMS	4-20-07	CHK'D BY:	BRH	
TITLE: FUSE HOLDER, HIGH AMP ANL M10 STUDS				
MATERIAL: GLASS FILLED NYLON			PART NO.	
COLOR: BLACK	DRG CLASS	REV L	ANB753M9N14	