

THE INFORMATION CONTAINED IN THIS DRAWING IS THE SOLE PROPERTY OF VTE INCORPORATED. ANY REPRODUCTION IN PART OR WHOLE WITHOUT THE WRITTEN PERMISSION OF VTE INCORPORATED IS PROHIBITED. VTE MAKES NO WARRANTY, EXPRESSED OR IMPLIED, AS TO THE SUITABILITY OF A PRODUCT FOR ANY INTENDED USE. THE CUSTOMER SHALL BEAR THE SOLE RESPONSIBILITY OF DETERMINING THE SUITABILITY OF ANY VTE PRODUCT FOR ITS END USE.

LTR.	REVISIONS	DATE	INT.
A	3853-004 WAS 3853-212	08-02-16	RAS
B	333N0N** WAS 333N0V**	08-22-16	MDL
C	3844-012 WAS 3844-003	11-04-16	JMM
D	ADDED ADDITIONAL INFORMATION FOR PROPER USE	2-19-18	RAS

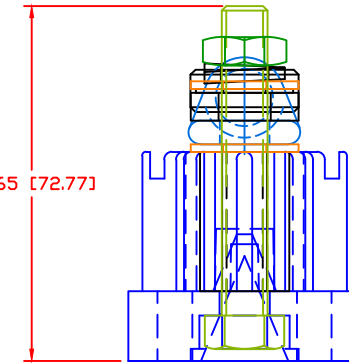
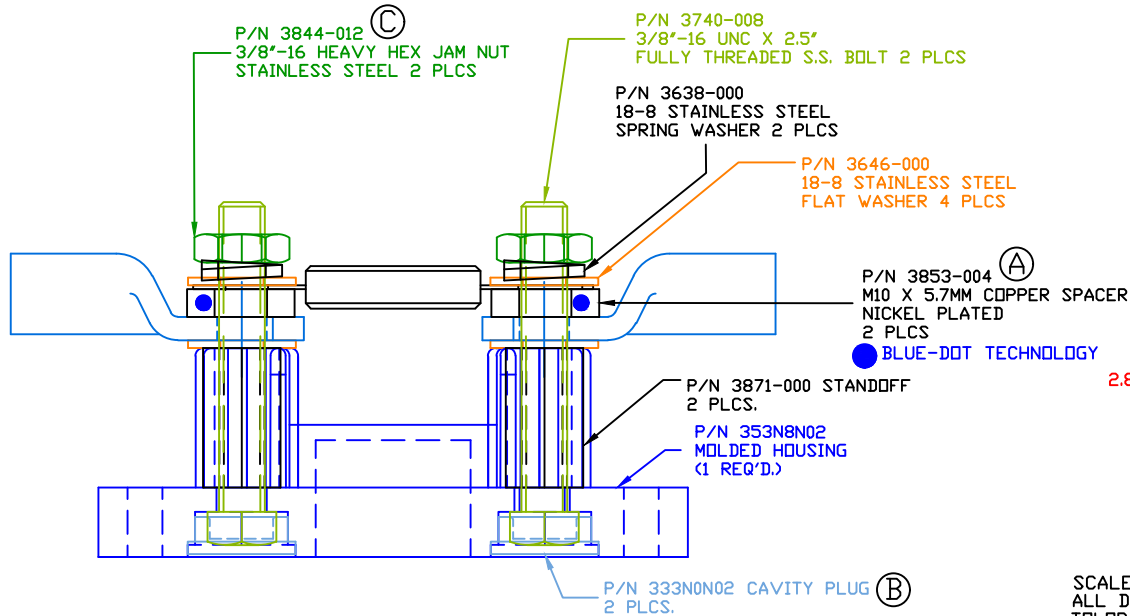
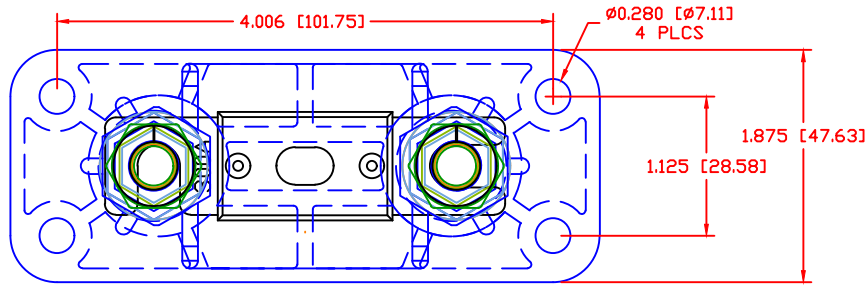

SCALE FACTOR : NONE
 ALL DIMENSIONS GIVEN AS: in [mm]
 TOLERANCES UNLESS OTHERWISE SPECIFIED :
 MOLDED PARTS: ±.030" [±0.8mm]
 HARDWARE ITEMS: ±.010" [±0.25mm]

MAXIMUM AMPERAGE: 750 AMPS @ 12VDC
 MAXIMUM VOLTAGE: 32VDC

MAXIMUM RECOMMENDED FASTENER TORQUE: $\text{\textcircled{D}}$
 STAINLESS HEAVY JAM HEX NUT: 180 IN./LBS. [20.3 NM]
 MATERIAL PART NO: 7111210502
 MATERIAL: GLASS FILLED NYLON
 VENDOR PART NO: HYLON N2015 HL NAT
 SPECIFIC GRAVITY: 1.23
 MELTING TEMP: 515 F [268 C]
 U.L. RATING: UL 94 HB

INCLUDES P-16808110001 BLUE DOT MULTI LABEL, 1 PER CONTAINER
 FUSE AND LUG TERMINALS ARE NOT INCLUDED, (SHOWN FOR REFERENCE ONLY)

		VTE Incorporated 5437 Robinson Road, P.O. Box 790 Pellston, Michigan 49769 Telephone: 1-800-527-9256, 231-539-8000 FAX: 231-539-0914	
		REF:	DATE:
CUSTOMER DIMS	12-14-14	CHK'D BY: BRH	
TITLE: FUSE HOLDER, HIGH AMP ANL 3/8" STUDS WITHOUT COVER SPECIAL FOR CALIFORNIA MFG.			
MATERIAL: GLASS FILLED NYLON		PART NO. ANB753X8N02	
COLOR: RED	DRG CLASS: REV D		