

THE INFORMATION CONTAINED IN THIS DRAWING IS THE SOLE PROPERTY OF VTE INCORPORATED. ANY REPRODUCTION IN PART OR WHOLE WITHOUT THE WRITTEN PERMISSION OF VTE INCORPORATED IS PROHIBITED. VTE MAKES NO WARRANTY, EXPRESSED OR IMPLIED, AS TO THE SUITABILITY OF A PRODUCT FOR ANY INTENDED USE. THE CUSTOMER SHALL BEAR THE SOLE RESPONSIBILITY OF DETERMINING THE SUITABILITY OF ANY VTE PRODUCT FOR ITS END USE.

LTR.	REVISIONS	DATE	INT.
A	3.07" WAS 3.25"	5-11-10	BRH
B	REDUCED FROM 550 AMP	11-17-15	RAS
C	ADDED TORQUE TAG	12-29-15	RAS
D	INCREASED FROM 350 AMP	1-01-16	RAS
E	MOVED TORQUE TAG TO OPPOSITE POST	1-27-16	RAS
F	3.09 WAS 3.07, UPDATED MATERIAL P/N	6-22-17	JMM
G	REDRAWN (ORIGINAL DRAWING 5-28-09)	11-17-17	RAS
H	UPDATED TORQUE VALUES FROM 180 IN-LBS [20.34 Nm]	2-03-18	RAS
I	ADDED IP65 STATEMENT	10-17-18	RAS

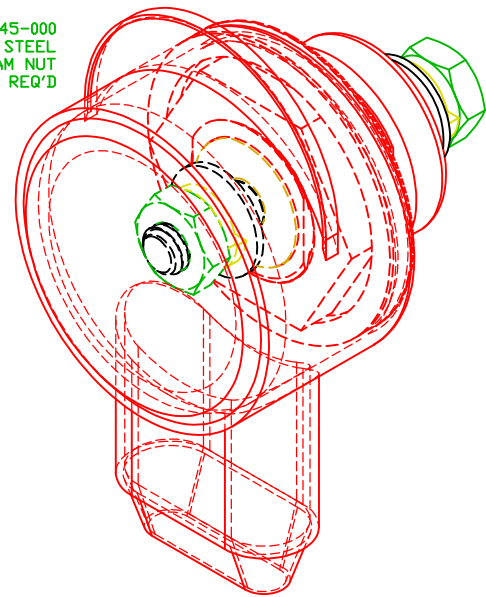
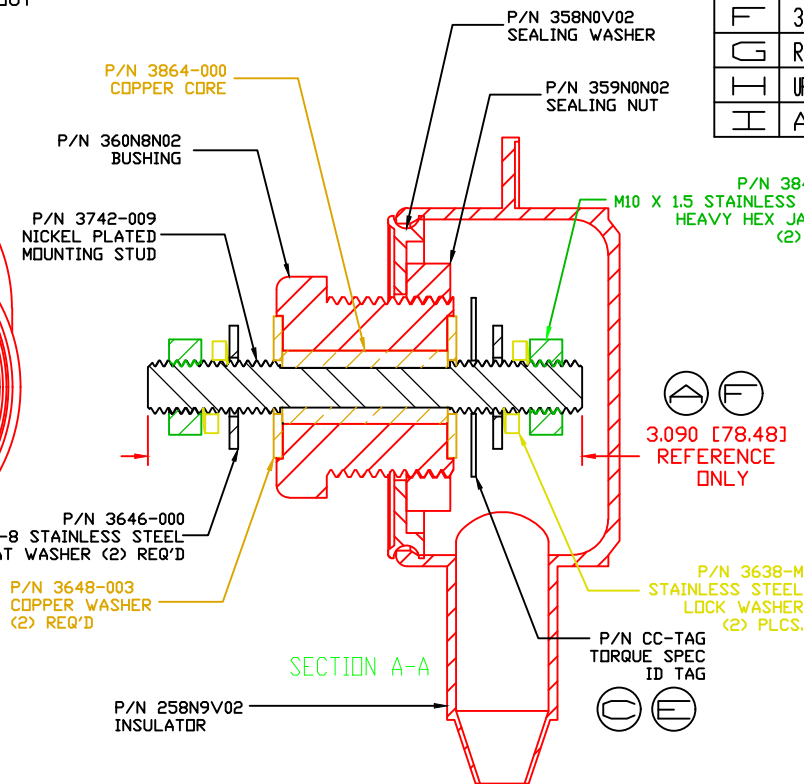
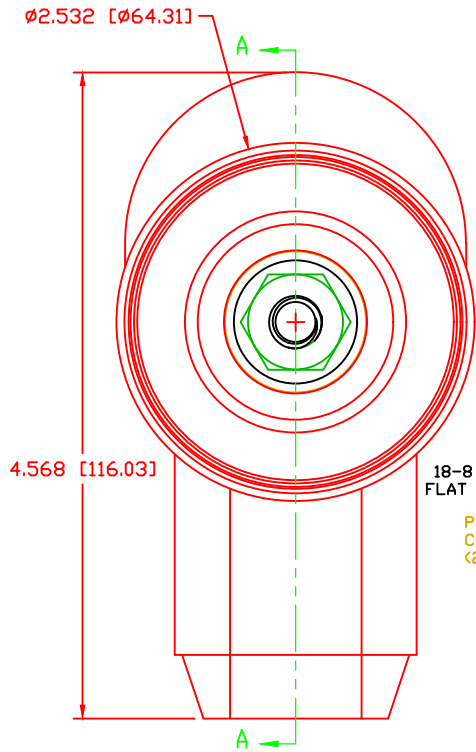
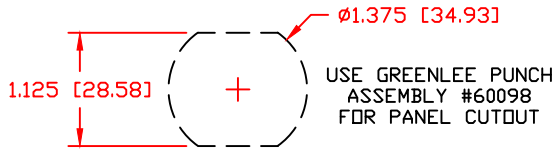

SCALE FACTOR : NONE  
 ALL DIMENSIONS GIVEN AS: in [mm]  
 TOLERANCES UNLESS OTHERWISE SPECIFIED :  
 MOLDED PARTS: ±.030" [±0.8mm]  
 HARDWARE ITEMS: ±.010" [±0.25mm]

- ⊕ MAXIMUM FASTENER TORQUES:
- ⊕ JAM NUTS: 212 IN-LBS [24.0 Nm]
- ⊕ SEALING NUT: 120 IN-LBS [13.5 Nm]
- CURRENT CARRYING CAPACITY:
- DUTY CYCLE:
- CURRENT CAPACITY:
- TEMPORARY MAX (12 MINUTES)
- MATERIAL PART NO:
- MATERIAL:
- VENDOR PART NO:
- SPECIFIC GRAVITY:
- MELTING TEMP:
- U.L. RATING:

( ASSEMBLY DESIGNED TO MEET IP65 REQUIREMENTS )

- 80%
- 4.3 Kw (360 AMP @ 12VDC) ⊕ ⊕
- 5.4 Kw (450 AMP @ 12VDC) ⊕ ⊕
- ⊕ 7111210502
- GLASS FILLED NYLON
- HYLON N2015 HL NAT
- 1.23
- 515 F [268 C]
- UL 94 HB

VTE Incorporated  
 5437 Robinson Road, P.O. Box 790  
 Pellston, Michigan 49769  
 Telephone: 1-800-527-9256, 231-539-8000  
 FAX: 231-539-0914

REF: CUSTOMER DIMS	DATE: 11-17-17	DRN BY: RAS	WEIGHT:
		CHK'D BY: PJK	
TITLE: WEATHER PROOF 10MM POWER BUSHING, COPPER CORE			
MATERIAL: GLASS FILLED NYLON		PART NO. CCB376M0NR02W	
COLOR: RED	DRG CLASS: REV I		