

SECTION A-A

PANEL CUT-OUT

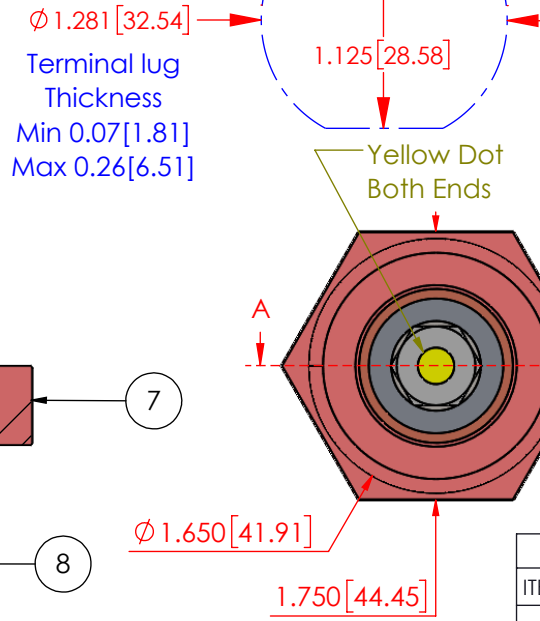

REVISIONS			
REV.	DESCRIPTION	DATE	APPROVED
A	Updated Electrical Values	3/30/2023	RAS
B	80 IN./LBS. [9.0Nm] was 120 IN./LBS. [13.56Nm]	9/16/2024	RAS
C	Added "Bulk Packed" Note	9/19/2024	RAS

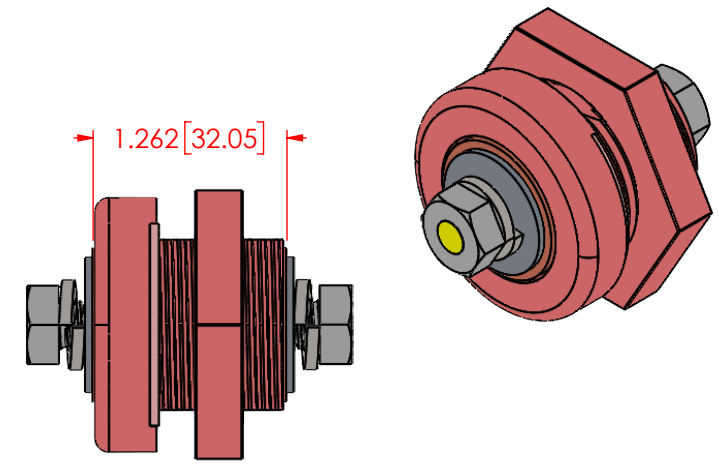

BULK PACKED SEPERATELY			
ITEM NO.	PART NUMBER	DESCRIPTION	QTY.
1	3960-005	Norseal Red Silicone Gasket	1

ITEM NO.	PART NUMBER	DESCRIPTION	QTY.
2	3731-004	8mm x 1.25 18-8 Stainless Steel Hex Bolt 18mm Long	2
3	3638-002	M8 18-8 Stainless Steel Lock Washer	2
4	3645-000	5/16" 18-8 Stainless Steel Flat Washer	2
5	3648-010	1/2" Copper Contact Washer	2
6	362N0N02	Nylon Power Bushing Housing (Red)	1
7	359N0N02	Glass Filled Nylon Locking Nut (Red)	1
8	3865-000	8mm x 1.25 Threaded Copper Core	1
9	3962-000	SBR Rubber Grommet	1

CABLE TEMP RATING :	60c	90c	105c	125c
CURRENT RATING @ 12vdc :	275A	380A	440A	490A
TEMPORARY MAX @ 12vdc :	305A	415A	475A	535A

MAXIMUM VOLTAGE : 48 VDC

MATERIAL PART NO: 7111210502
 MATERIAL: GLASS FILLED NYLON
 VENDOR PART NO: HYLON N2015 NAT

MAX M8 FASTENER TORQUE: 144 IN./LBS. [16.27 Nm]
 MAX NYLON NUT TORQUE: 80 IN./LBS. [9.0 Nm]

Assembly Weight : 0.24 Lbs. [108.8g]

Assembly Color : Red

ALL DIMENSIONS GIVEN AS : INCH [METRIC]
 TOLERANCES UNLESS OTHERWISE SPECIFIED :
 MOLDED PRODUCTS : ±.030" / ±0.8mm
 HARDWARE PRODUCTS : ±.010" / ±0.25mm

PRINTED COPIES ARE NOT CONTROLLED
PROPRIETARY AND CONFIDENTIAL
 THE INFORMATION CONTAINED IN THIS DRAWING IS THE SOLE PROPERTY OF VTE INCORPORATED. ANY REPRODUCTION IN PART OR AS A WHOLE WITHOUT THE WRITTEN PERMISSION OF VTE INCORPORATED PROHIBITED.



VTE INCORPORATED

5437 Robinson Road, P.O. Box 790
 Pellston, Michigan 49769 USA
 Telephone : 1-800-527-9256, 231-539-8000
 Fax : 231-539-0914, Efax : 231-344-5914

REV	C	NAME	DATE
DRAWN BY:	RAS	3-9-23	
CHECKED BY:	PJK	3-9-23	
SIZE	A	DO NOT SCALE DRAWING	

TITLE: M8 Waterproof Power Bushing with 18mm Long Bolts

DWG. NO. **ICB088N02**

