

REVISIONS			
REV.	DESCRIPTION	DATE	APPROVED

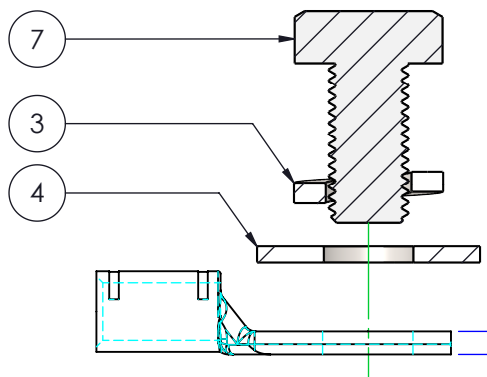

PANEL CUT-OUT

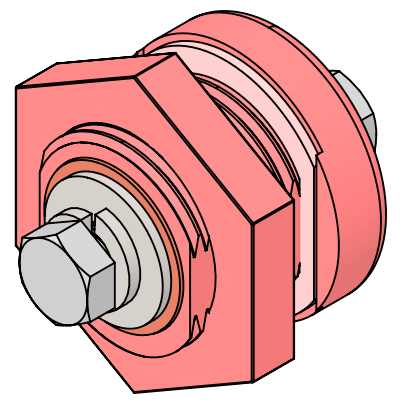
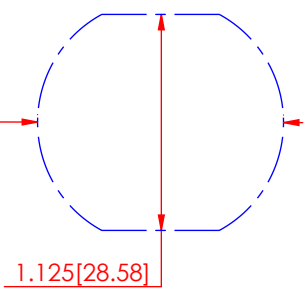

0.1875 [4.76]
Max Terminal Lug
Thickness

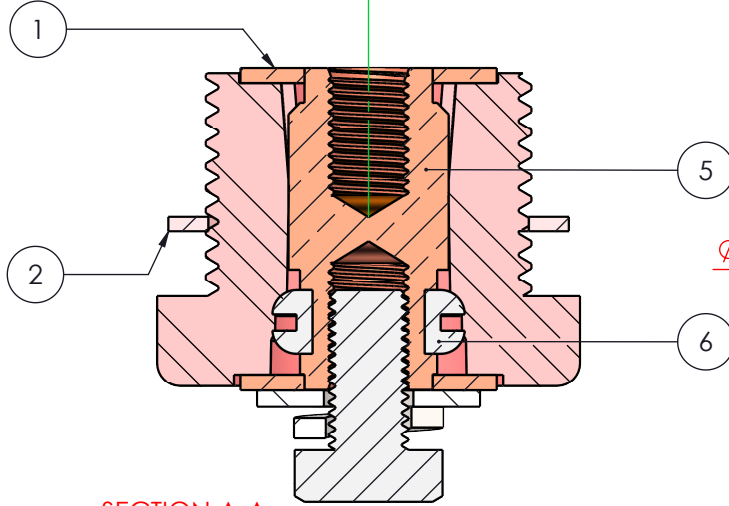
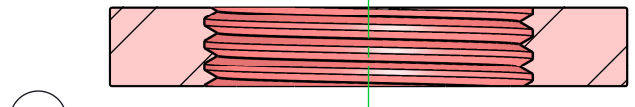

SECTION A-A

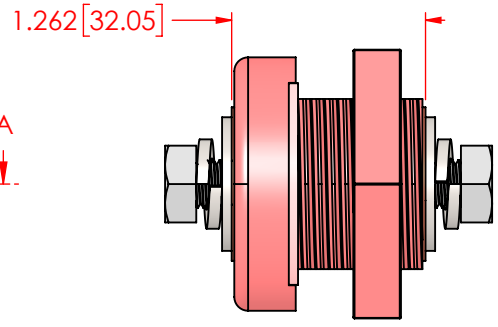
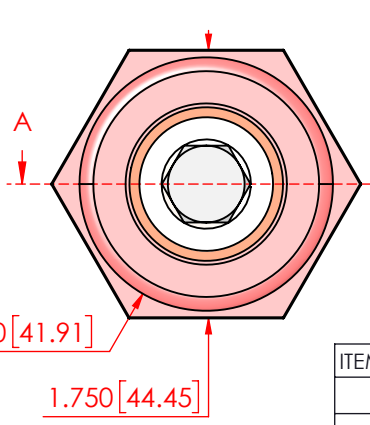

ITEM NO.	PART NUMBER	DESCRIPTION	QTY.
1	3648-010	1/2" Copper Contact Washer	2
2	3960-005	Norseal Red Silicone Gasket	1
3	3638-002	M8 18-8 Stainless Steel Lock Washer	2
4	3645-000	5/16" 18-8 Stainless Steel Flat Washer	2
5	3865-002	5/16"-24 Threaded Copper Core	1
6	3962-000	EPDM Rubber Grommet	1
7	3730-016	5/16"-24 18-8 Stainless Steel Bolt .625" Long	2
8	359N0N02	Glass Filled Nylon Locking Nut (Red)	1
9	362N0N02	Nylon Power Bushing Housing (Red)	1

CABLE TEMP RATING :	60c	90c	105c	125c
CURRENT RATING @ 12vdc :	275A	380A	440A	490A
TEMPORARY MAX @ 12vdc :	305A	415A	475A	535A

MAXIMUM VOLTAGE : 48 VDC

MATERIAL PART NO: 7111210502
 MATERIAL: GLASS FILLED NYLON
 VENDOR PART NO: HYLON N2015 NAT

MAX 5/16" FASTENER TORQUE: 144 IN./LBS. [16.27 Nm]
 MAX NYLON NUT TORQUE: 120 IN./LBS. [13.56 Nm]

Assembly Weight : 0.24 Lbs. [108.8g]
 Assembly Color : Red
 ALL DIMENSIONS GIVEN AS : INCH [METRIC]
 TOLERANCES UNLESS OTHERWISE SPECIFIED :
 MOLDED PRODUCTS : ±.030" / ±0.8mm
 HARDWARE PRODUCTS : ±.010" / ±0.25mm

PRINTED COPIES ARE NOT CONTROLLED
PROPRIETARY AND CONFIDENTIAL
 THE INFORMATION CONTAINED IN THIS
 DRAWING IS THE SOLE PROPERTY OF
 VTE INCORPORATED. ANY REPRODUCTION
 IN PART OR AS A WHOLE WITHOUT THE WRITTEN
 PERMISSION OF VTE INCORPORATED PROHIBITED.



VTE INCORPORATED

5437 Robinson Road, P.O. Box 790
 Pellston, Michigan 49769 USA
 Telephone : 1-800-527-9256, 231-539-8000
 Fax : 231-539-0914, Efax : 231-344-5914

REV	NAME	DATE
SIZE	DRAWN BY: RAS	3-22-23
A	CHECKED BY: PJK	3-22-23
	DO NOT SCALE DRAWING	

TITLE: 5/16" Waterproof Power Bushing with .625" Long Bolts

DWG. NO. **ICB316N02**