

THE INFORMATION CONTAINED IN THIS DRAWING IS THE SOLE PROPERTY OF VTE INCORPORATED. ANY REPRODUCTION IN PART OR WHOLE WITHOUT THE WRITTEN PERMISSION OF VTE INCORPORATED IS PROHIBITED. VTE MAKES NO WARRANTY, EXPRESSED OR IMPLIED, AS TO THE SUITABILITY OF A PRODUCT FOR ANY INTENDED USE. THE CUSTOMER SHALL BEAR THE SOLE RESPONSIBILITY OF DETERMINING THE SUITABILITY OF ANY VTE PRODUCT FOR ITS END USE.

| LTR. | REVISIONS   | DATE     | INT. |
|------|---|----------|------|
| A    | REVISED DRAWING TO AGREE WITH PARTS AS MANUFACTURED | 11-06-12 | BRH  |
| B    | REVISED DIMENSION FROM .134 [3.40]                  | 3-21-18  | RAS  |
| C    | REVISED MATERIAL INFORMATION                        | 07-17-18 | RAS  |

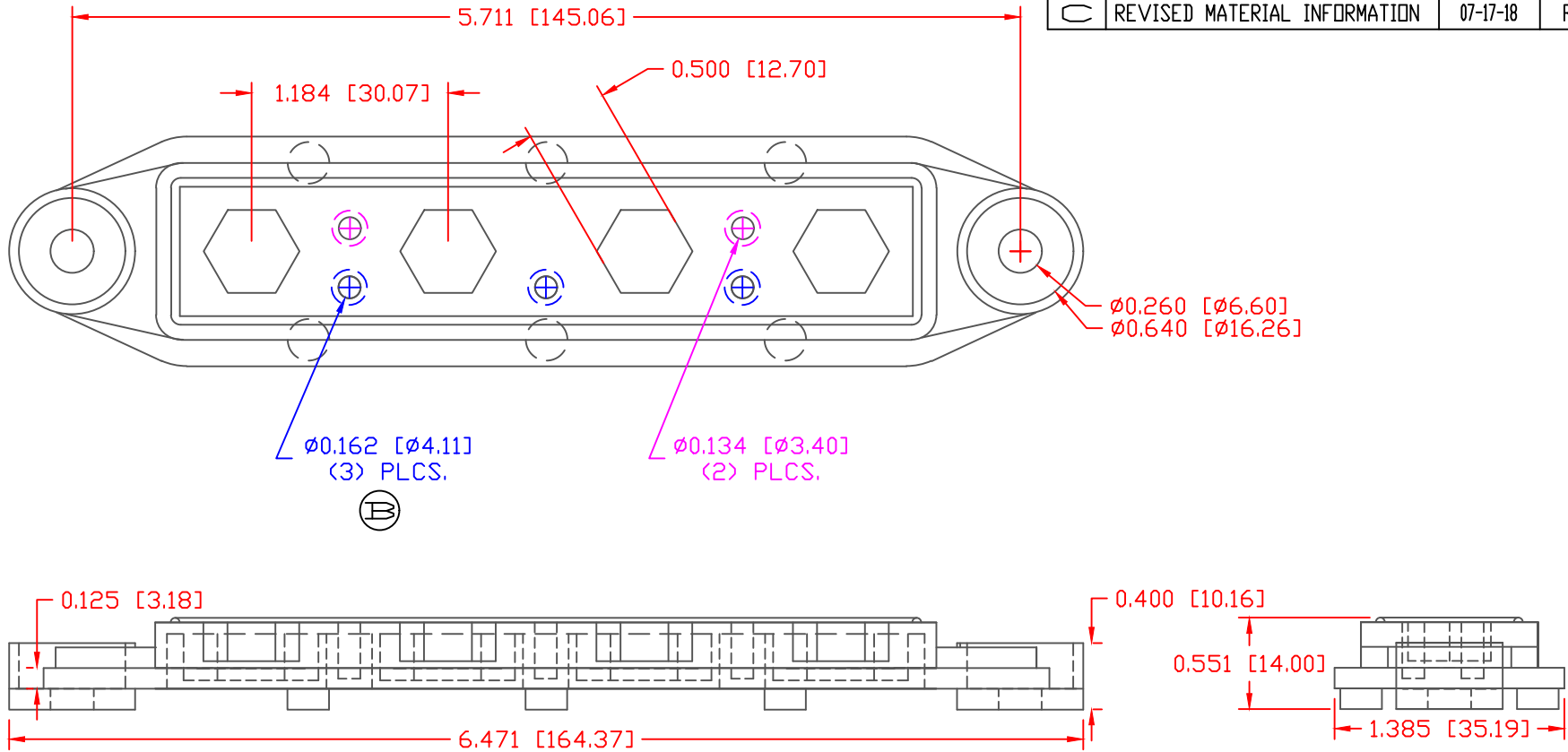

SCALE FACTOR : NONE  
 ALL DIMENSIONS GIVEN AS: in [mm]  
 TOLERANCES UNLESS OTHERWISE SPECIFIED :  
 MOLDED PARTS:  $\pm 0.030$ " [ $\pm 0.8$ mm]  
 HARDWARE ITEMS:  $\pm 0.010$ " [ $\pm 0.25$ mm]

MATERIAL PART NO:  
 MATERIAL:  
 VENDOR PART NO:  
 SPECIFIC GRAVITY:  
 MELTING TEMP:  
 U.L. RATING:

7111210502  
 GLASS FILLED NYLON  
 NYLON N2015 HL NAT  
 1.23  
 515 F [268 C]  
 UL 94 HB

DO NOT SCALE

|   |           |   |                |
|---|-----------|---|----------------|
|  |           | <b>VTE Incorporated</b><br>5437 Robinson Road, P.O. Box 790<br>Pellston, Michigan 49769<br>Telephone: 1-800-527-9256, 231-539-8000<br>FAX: 231-539-0914 |                |
|   |           | REF: QA DIMS  | DATE: 08-18-10 |
|   |           | CHK'D BY: BRH   |                |
| TITLE: BASEPLATE, 4 POINT BUS 5/16"   |           |   |                |
| MATERIAL: GLASS FILLED NYLON  |           | PART NO. 344312N02  |                |
| COLOR: RED  | DRG CLASS | REV C   |                |