

THE INFORMATION CONTAINED IN THIS DRAWING IS THE SOLE PROPERTY OF VTE INCORPORATED. ANY REPRODUCTION IN PART OR WHOLE WITHOUT THE WRITTEN PERMISSION OF VTE INCORPORATED IS PROHIBITED. VTE MAKES NO WARRANTY, EXPRESSED OR IMPLIED, AS TO THE SUITABILITY OF A PRODUCT FOR ANY INTENDED USE. THE CUSTOMER SHALL BEAR THE SOLE RESPONSIBILITY OF DETERMINING THE SUITABILITY OF ANY VTE PRODUCT FOR ITS END USE.

LTR.	REVISIONS	DATE	INT.
A	DEPTH OF HEX INCREASED	02-14-16	BRH
B	ADDED MATERIAL ASSEMBLY	12-12-16	JMM
C	REVISED MATERIAL INFORMATION	07-17-18	RAS

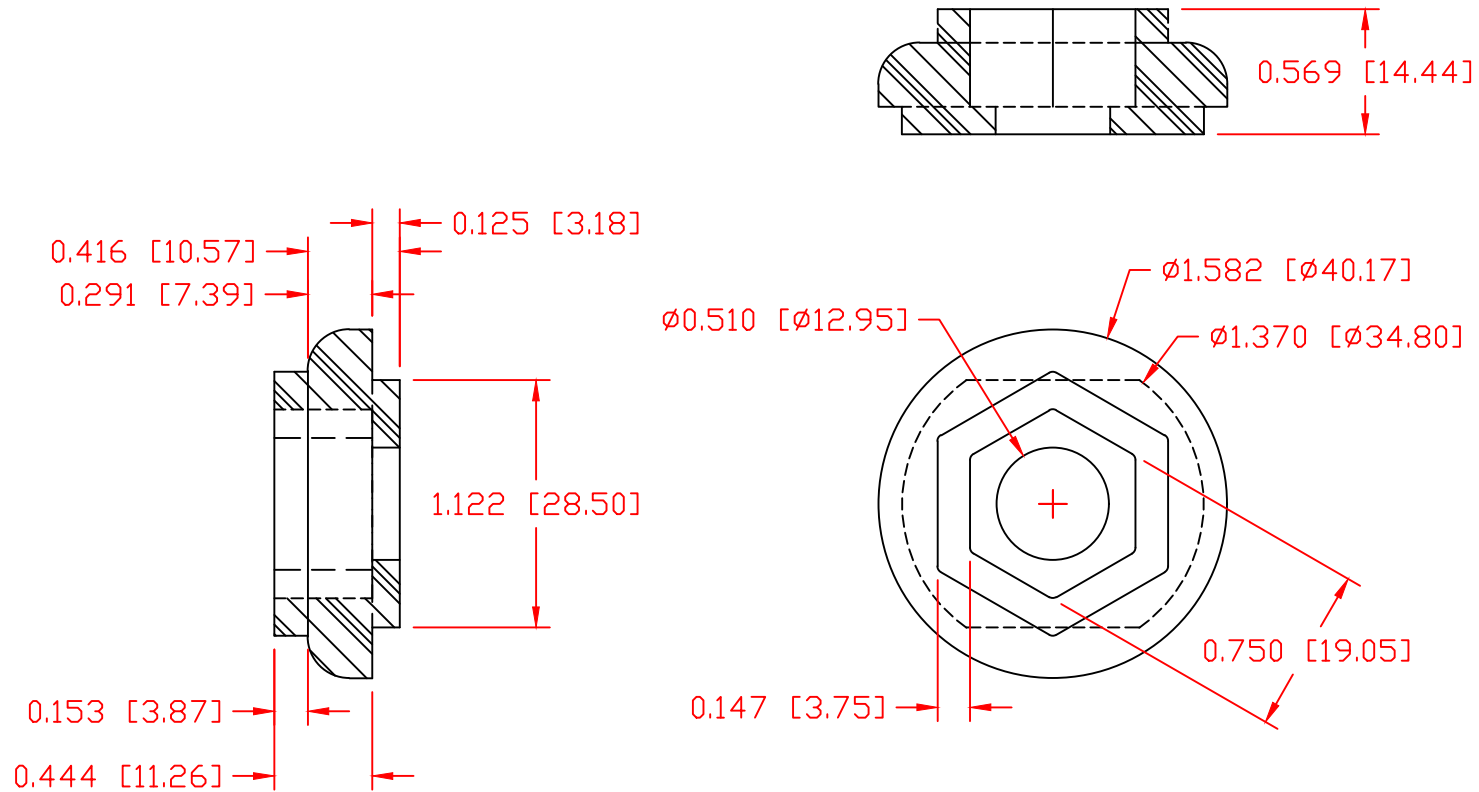

ALL DIMENSIONS GIVEN AS: in [mm]
 MOLDED PARTS: ±.030" [±0.8mm]
 HARDWARE ITEMS: ±.010" [±0.25mm]

MATERIAL PART NO:
 MATERIAL:
 VENDOR PART NO:
 SPECIFIC GRAVITY:
 MELTING TEMP:
 U.L. RATING:

7111210502
 GLASS FILLED NYLON
 NYLON N2015 HL NAT
 1.23
 515 F [268 C]
 UL 94 HB

DO NOT SCALE

		VTE Incorporated 5437 Robinson Road, P.O. Box 790 Pellston, Michigan 49769 Telephone: 1-800-527-9256, 231-539-8000 FAX: 231-539-0914	
		REF: QA DIMS	DATE: 1-16-03
TITLE: INNER PANEL BUSHING FOR 1/2" POWER STUD			
MATERIAL: GLASS FILLED NYLON		PART NO. 3550N02	
COLOR: RED	DRG CLASS: REV C		