

THE INFORMATION CONTAINED IN THIS DRAWING IS THE SOLE PROPERTY OF VTE INCORPORATED. ANY REPRODUCTION IN PART OR WHOLE WITHOUT THE WRITTEN PERMISSION OF VTE INCORPORATED IS PROHIBITED.

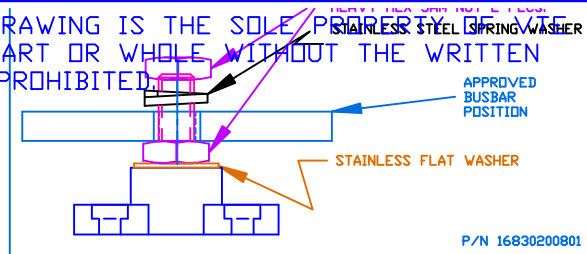

LTR.	REVISED	DATE
1	ADDED MATERIAL AND PERFORMANCE NOTES	22JAN04
2	REVISED PERFORMANCE NOTES	23FEB04
3	3844-002 WAS 3844	18MAY05
4	REPLACED (1)-3844-002 WITH (1)-3844	01SEP05
5	ADDED OPTIONAL CONSTRUCTION NOTE AND -000 SUFFIXES	04APR06

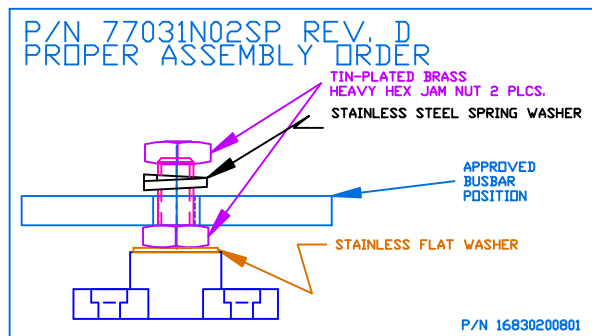
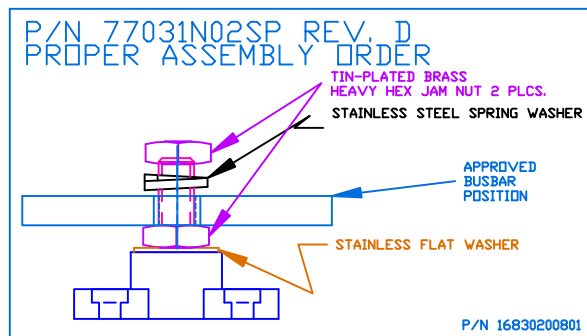
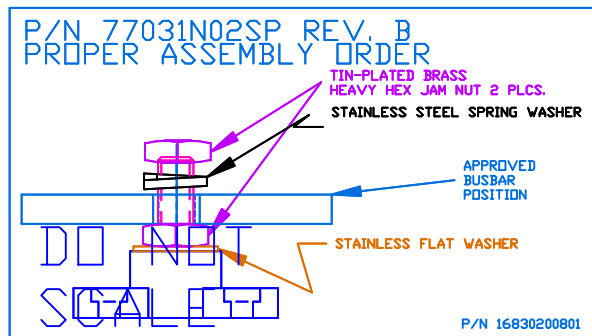
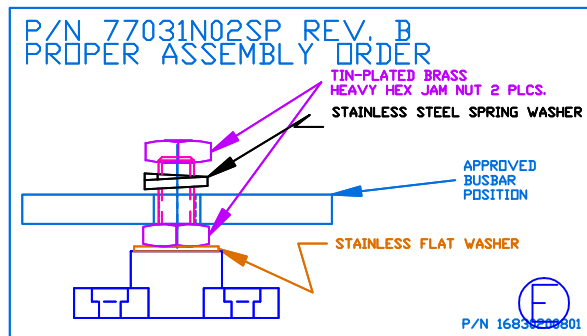

TOLERANCE UNLESS OTHERWISE SPECIFIED: $\pm 0.30^{\circ} / \pm 0.8\text{mm}$
 RADIAL DIAMETERS TO BE MEASURED OVER MANDRELS,
 RING GAGES OR PIN GAGES OF SUITABLE SIZE

BASE MATERIAL: GLASS-REINFORCED NYLON
 BASE MATERIAL U.L. RATING: 94 HB
 DIELECTRIC STRENGTH: 630 VOLTS/MIL PER ASTM D149
 CURRENT RATING: 250 AMPS
 TEMP. RISE AT LOAD: 52 DEG. F.
 RECOMMENDED MAXIMUM TORQUE: 12 FT./LBS. (144 IN./LBS.)

VTE Incorporated
 5437 Robinson Road, P.O. Box 790
 Pellston, Michigan 49769
 Telephone: 1-800-527-9256, 231-539-8000
 FAX: 231-539-0914

REF: ***	DATE: 09APR03	DRN BY: BRH	WEIGHT: ***
TITLE: 3/8" SMALL JUNCTION POST		CHK'D BY: BRH	SCALE: NONE
MATERIAL: NOTED		PART NO. 77037 N02	
COLOR: RED	DRG CLASS		