

PROPRIETARY RIGHTS ARE CLAIMED FOR THE MATERIAL DISCLOSED IN THIS DRAWING.

LTR.	REVISIONS	DATE
∧	ADDED .12 RADIUS	03-17-98

SEAL OPTIONS
SEAL THICKNESS = .8

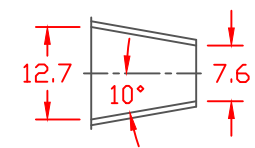
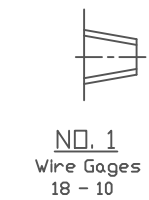
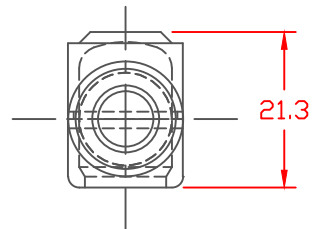
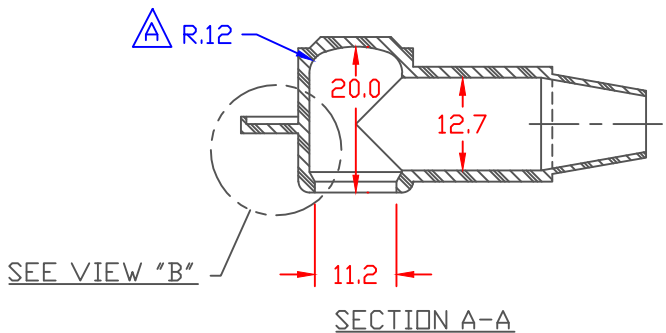

TYP. WALL THICKNESS = 1.5
SEAL NO. 2 SHOWN

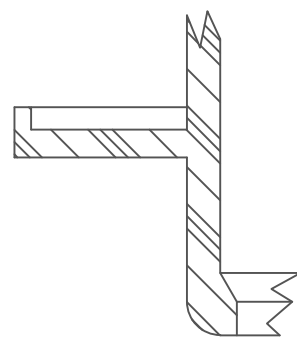
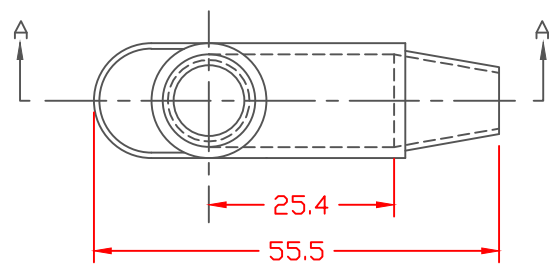



VIEW "B"
SCALE: 3" = 1"
TOLERANCE UNLESS OTHERWISE SPECIFIED: ±.030"/±0.8mm
RADIAL DIAMETERS TO BE MEASURED OVER MANDRELS,
RING GAGES OR PIN GAGES OF SUITABLE SIZE

Material:
Material Part No

Thermoplastic Elastomer
(Santoprene 21-64 or Equivalent)
Durometer 67 to 73 Shore A

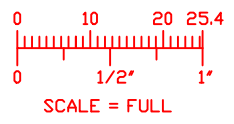
NON-STANDARD ITEM
AVAILABLE BY SPECIAL
ORDER ONLY



		VTE Incorporated 5437 Robinson Road, P.O. Box 790 Pellston, Michigan 49769 Telephone: 1-800-527-9256, 231-539-8000 FAX: 231-539-0914	
		REF:	DATE:
	10-5-93	CHK'D BY:	.011 Lbs. / 4.99 G.
TITLE: TERMINAL INSULATOR CAP			
MATERIAL:		PART NO.	
		212N2T14	
COLOR:	DRG CLASS		