

PROPRIETARY RIGHTS ARE CLAIMED FOR THE MATERIAL DISCLOSED IN THIS DRAWING.

LTR.	REVISIONS	DATE
✂	*****	00-00-98

SEAL OPTIONS
SEAL THICKNESS = .8

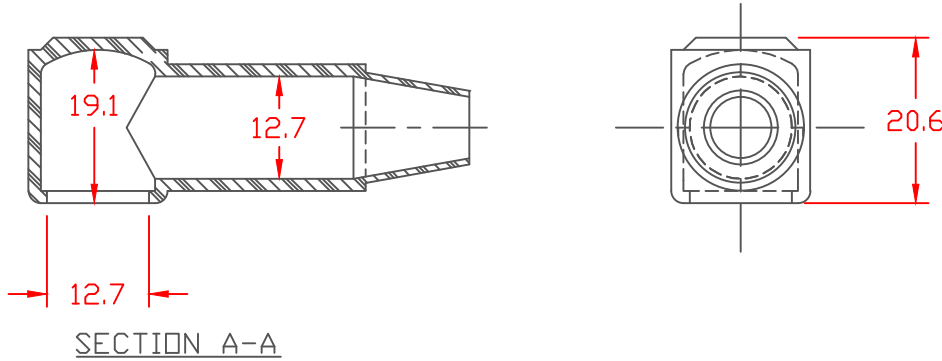

TYP. WALL THICKNESS = 1.5
SEAL NO. 2 SHOWN

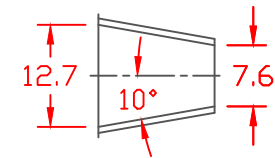

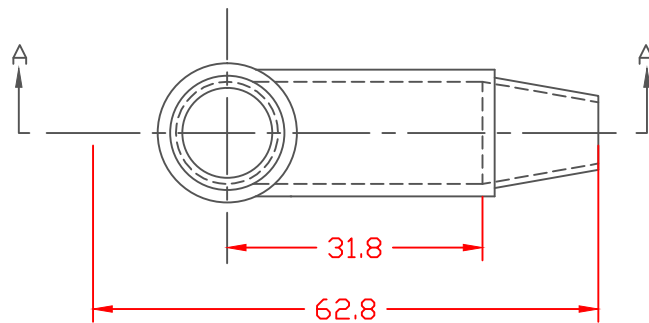

NO. 2
Cable Gages
8 - 2

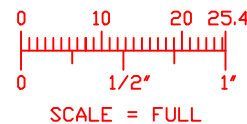

TOLERANCE UNLESS OTHERWISE SPECIFIED: ± 0.030 / ± 0.8 mm
RADIAL DIAMETERS TO BE MEASURED OVER MANDRELS,
RING GAGES OR PIN GAGES OF SUITABLE SIZE

VTE Material Part No:	1101700102
Material:	RED PVC
Material Part No:	M1170 FR RD or Equivalent
Max. Operating Temp:	105 C
Shore Durometer:	"A" 15 SEC. 70+/-5
Specific Gravity:	1.34
Ult. Elongation %:	275 Minimum
Tensile Strength PSI:	1600 PSI Minimum
U.L. Rating:	94 V0



		VTE Incorporated 5437 Robinson Road, P.O. Box 790 Pellston, Michigan 49769 Telephone: 1-800-527-9256, 231-539-8000 FAX: 231-539-0914	
		REF:	DATE: 10-5-93
MATERIAL:		CHK'D BY:	
TITLE: TERMINAL INSULATOR CAP W/O TAB		PART NO. 214E2F02 X1	
COLOR:	DRG CLASS		