

THE INFORMATION CONTAINED IN THIS DRAWING IS THE SOLE PROPERTY OF VTE INCORPORATED. ANY REPRODUCTION IN PART OR WHOLE WITHOUT THE WRITTEN PERMISSION OF VTE INCORPORATED IS PROHIBITED.

LTR.	REVISIONS	DATE
≠	*****	00-000-00

P/N 3611
 5/16"-18
 Stainless Steel
 Nylon Insert Locknut

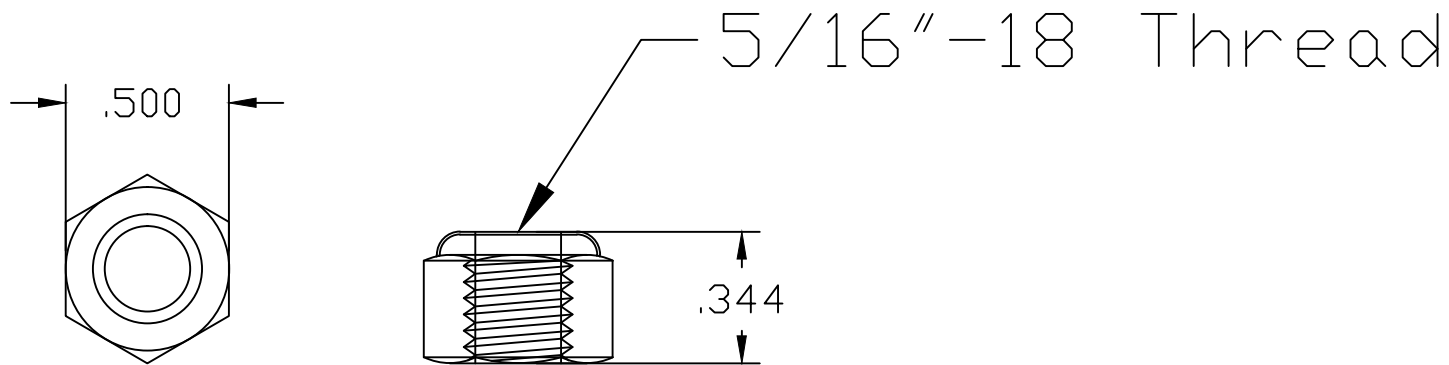

TOLERANCE UNLESS OTHERWISE SPECIFIED:
 HARDWARE ITEMS: ±.010"/±0.25mm
 RADIAL DIAMETERS TO BE MEASURED OVER MANDRELS,
 RING GAGES OR PIN GAGES OF SUITABLE SIZE

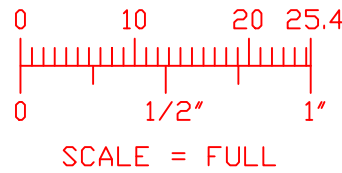

VTE Incorporated
 5437 Robinson Road, P.O. Box 790
 Pellston, Michigan 49769
 Telephone: 1-800-527-9256, 231-539-8000
 FAX: 231-539-0914

REF: *****	DATE: 20OCT08	DRN BY: BRH CHK'D BY: BRH	WEIGHT: *****
TITLE: 5/16"-18 S.S. Nylon Insert Locknut for 8-D kit			SCALE:
MATERIAL:		PART NO.	
COLOR: *****	DRG CLASS *****	3611	