

PROPRIETARY RIGHTS ARE CLAIMED FOR THE INFORMATION DISCLOSED IN THIS DRAWING. RELEASE OF THIS DESIGN CONCEPT TO ANY THIRD PARTY CONSTITUTES A VIOLATION OF OUR DEVELOPMENT AGREEMENT.

LTR.	REVISIONS	DATE
REL	NEW DESIGN FOR 16 AND 25mm CABLE	12-09-99

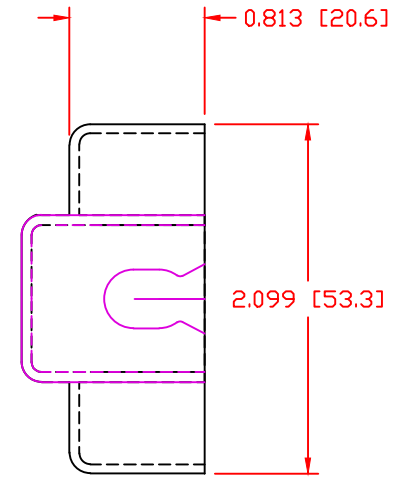
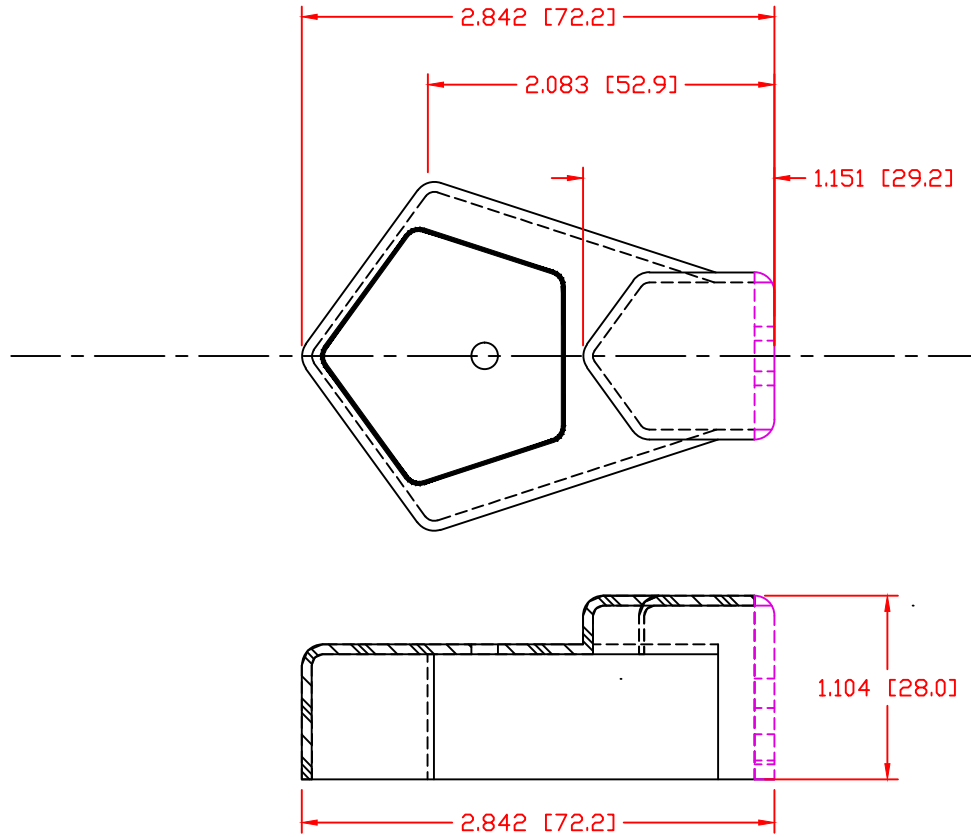

436S4

DESIGNED TO FIT 16 OR 25 mm² METRIC CABLE
 FITS THE FOLLOWING BATTERIES:

UPS 12-100 WITH 16 AND 25 MM² CABLE

TOLERANCE UNLESS OTHERWISE SPECIFIED: ±.030"/±0.8mm
 RADIAL DIAMETERS TO BE MEASURED OVER MANDRELS,
 RING GAGES OR PIN GAGES OF SUITABLE SIZE



VTE Incorporated
 5437 Robinson Road, P.O. Box 790
 Pellston, Michigan 49769
 Telephone: 1-800-527-9256, 231-539-8000
 FAX: 231-539-0914

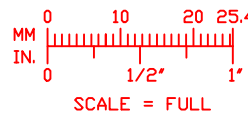

REF: *****	DATE: 06-15-99	DRN BY: BRH	WEIGHT: *****
TITLE: BATTERY TERMINAL INSULATOR		CHK'D BY:	SCALE: NONE
MATERIAL: *****	PART NO. 436S4H14		
COLOR: *****	DRG CLASS *****		