

PROPRIETARY RIGHTS ARE CLAIMED FOR THE INFORMATION DISCLOSED IN THIS DRAWING. RELEASE OF THIS DESIGN CONCEPT TO ANY THIRD PARTY CONSTITUTES A VIOLATION OF OUR DEVELOPMENT AGREEMENT.

LTR.	REVISIONS	DATE
△	ADDED CUTOFF FOR RISER	10-18-99

TYP. WALL THICKNESS = .06" (1.5mm)

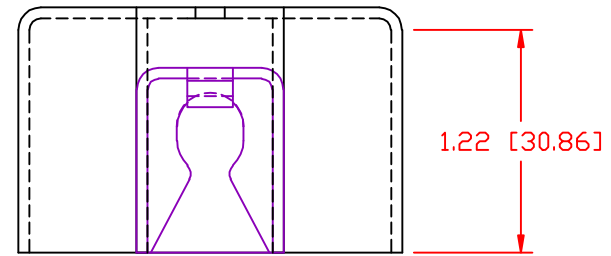
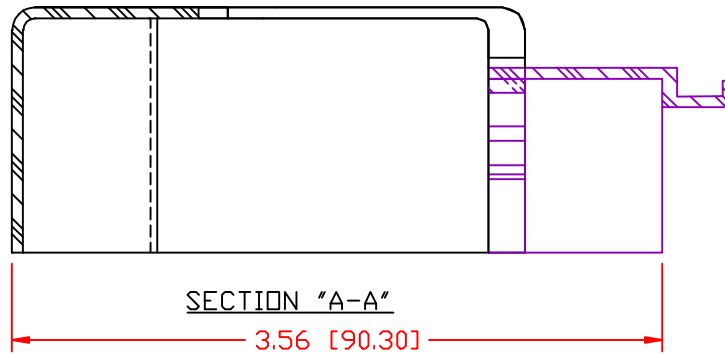
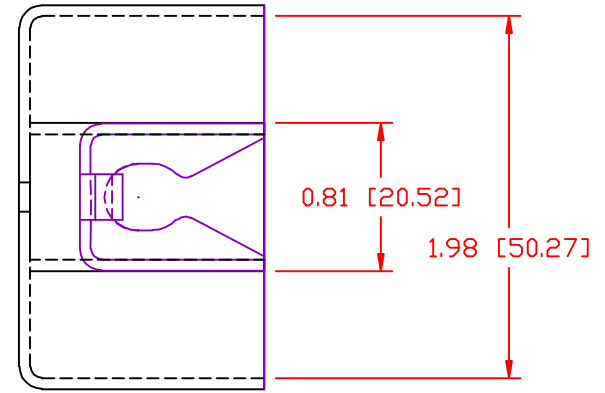
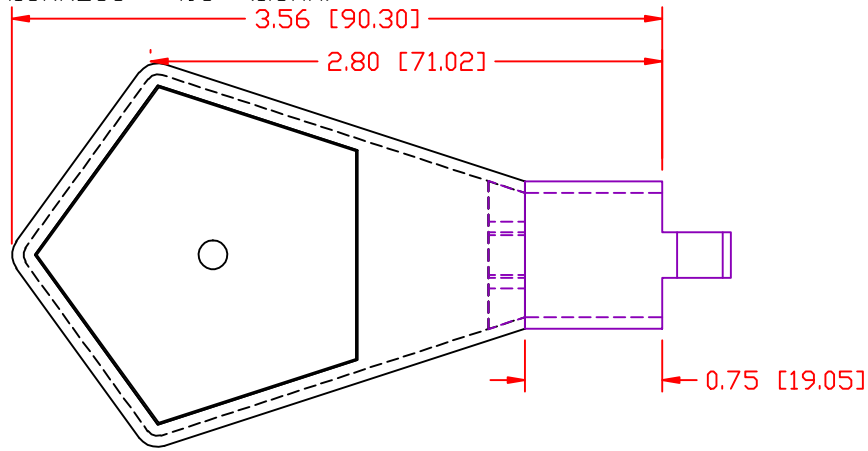

437N4  
DESIGNED TO FIT: 25 mm<sup>2</sup> METRIC CABLE

**MATERIAL: HALOGEN FREE, FIRE RETARDANT THERMOPLASTIC OLEFIN**  
**ELONGATION: 200%**  
**MEETS: U.L. 94-V2**  
**LIMITING OXYGEN INDEX: 37%**  
**COLOR: BLACK**  
**SPECIFIC GRAVITY: 1.05 - 1.10**  
**MINIMUM TENSILE STRENGTH: 1500 PSI**

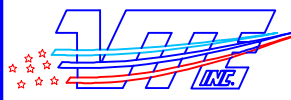

TOLERANCE UNLESS OTHERWISE SPECIFIED: ±.030"/±0.8mm  
 RADIAL DIAMETERS TO BE MEASURED OVER MANDRELS,  
 RING GAGES OR PIN GAGES OF SUITABLE SIZE

		<b>VTE Incorporated</b> 5437 Robinson Road, P.O. Box 790 Pellston, Michigan 49769 Telephone: 1-800-527-9256, 231-539-8000 FAX: 231-539-0914	
		REF: ****	DATE: 06-15-99
TITLE: BATTERY TERMINAL INSULATOR			SCALE: NONE
MATERIAL: *****	PART NO. 437N4H14		
COLOR: ****	DRG CLASS: ****		