

PROPRIETARY RIGHTS ARE CLAIMED FOR THE INFORMATION DISCLOSED IN THIS DRAWING. RELEASE OF THIS DESIGN CONCEPT TO ANY THIRD PARTY CONSTITUTES A VIOLATION OF OUR DEVELOPMENT AGREEMENT.

LTR.	REVISIONS	DATE
⤴	ADDED CUTOFF FOR RISER	10-18-99

TYP. WALL THICKNESS = .06" (1.5mm)

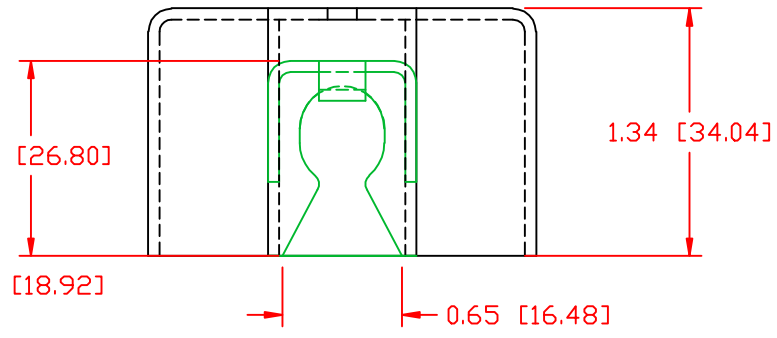
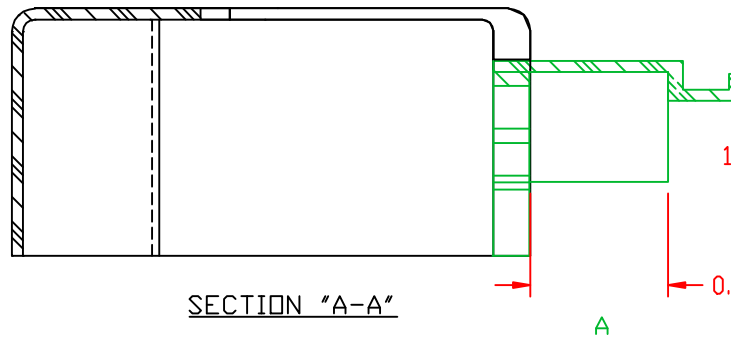
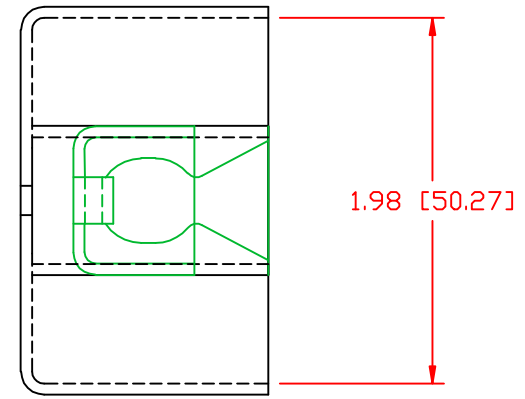
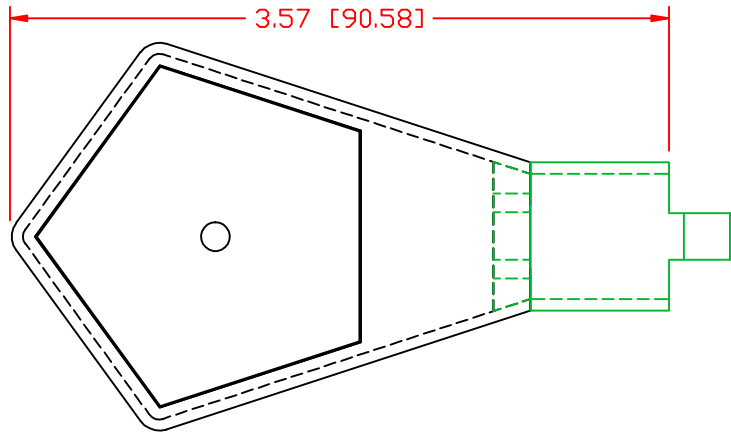

437N5

DESIGNED TO FIT 35 OR 50mm² METRIC CABLE
 FITS THE FOLLOWING BATTERIES:
 UPS 12-140 WITH 35 AND 50mm² CABLE

MATERIAL: HALOGEN FREE, FIRE RETARDANT THERMOPLASTIC OLEFIN
ELONGATION: 200%
MEETS: U.L. 94-V2
LIMITING OXYGEN INDEX: 37%
COLOR: BLACK
SPECIFIC GRAVITY: 1.05 - 1.10
MINIMUM TENSILE STRENGTH: 1500 PSI



TOLERANCE UNLESS OTHERWISE SPECIFIED: ±.030"/±0.8mm
 RADIAL DIAMETERS TO BE MEASURED OVER MANDRELS,
 RING GAGES OR PIN GAGES OF SUITABLE SIZE

VTE Incorporated
 5437 Robinson Road, P.O. Box 790
 Pellston, Michigan 49769
 Telephone: 1-800-527-9256, 231-539-8000
 FAX: 231-539-0914

REF: *****	DATE: 06-15-99	DRN BY: BRH	WEIGHT: 18.3 g
TITLE: BATTERY TERMINAL INSULATOR			SCALE: NONE
MATERIAL: *****	PART NO. 437N5H14		
COLOR: *****	DRG CLASS *****		