

PROPRIETARY RIGHTS ARE CLAIMED FOR THE MATERIAL DISCLOSED IN THIS DRAWING.

TYP. WALL THICKNESS = 2.5

LTR.	REVISIONS	DATE
≠	*****	00-00-98

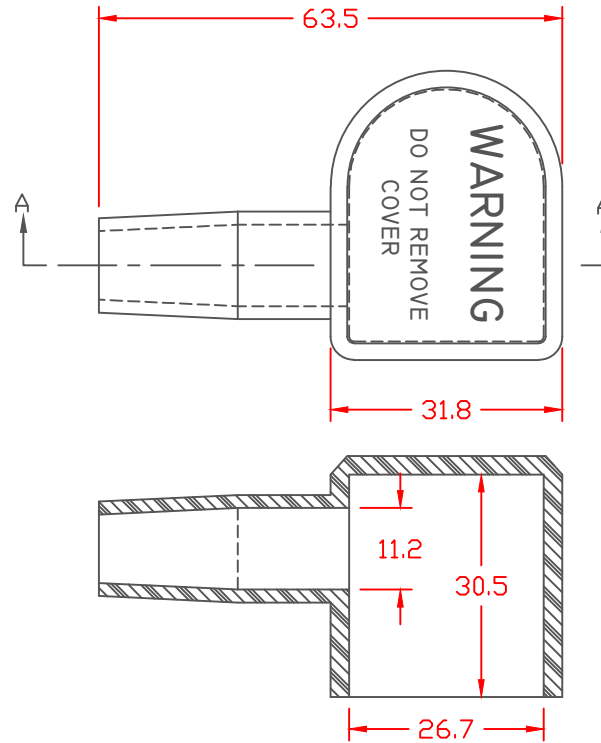
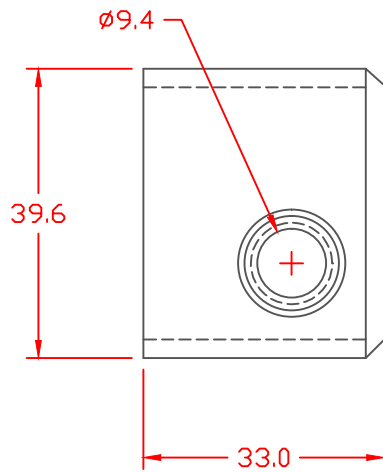

SECTION A-A

TOLERANCE UNLESS OTHERWISE SPECIFIED: ±.030"/±0.8mm
 RADIAL DIAMETERS TO BE MEASURED OVER MANDRELS,
 RING GAGES OR PIN GAGES OF SUITABLE SIZE

VTE Material Part No:
 Material:
 Material Part No
 Max. Operating Temp:
 Shore Durometer
 Specific Gravity:
 Ult. Elongation %:
 Tensile Strength PSI:
 U.L. Rating:

1101700114
 BLACK PVC
 M1170-FR or Equivalent
 105 C
 "A" 15 SEC. 70+/-5
 1.34
 275 Minimum
 1600 PSI Minimum
 94 V0



	VTE Incorporated 5437 Robinson Road, P.O. Box 790 Pellston, Michigan 49769 Telephone: 1-800-527-9256, 231-539-8000 FAX: 231-539-0914		
	REF:	DATE:	DRN BY:

	3-30-98	CJC	04 LBS. / 18.3 G.
--	---------	-----	-------------------

TITLE: U-1 BATTERY TERMINAL BOOT

MATERIAL:	PART NO.
COLOR:	DRG CLASS
	444L8F14