

PROPRIETARY RIGHTS ARE CLAIMED FOR THE MATERIAL DISCLOSED IN THIS DRAWING.

TYP. WALL THICKNESS = 2.5

LTR.	REVISIONS	DATE
≠	*****	00-00-98

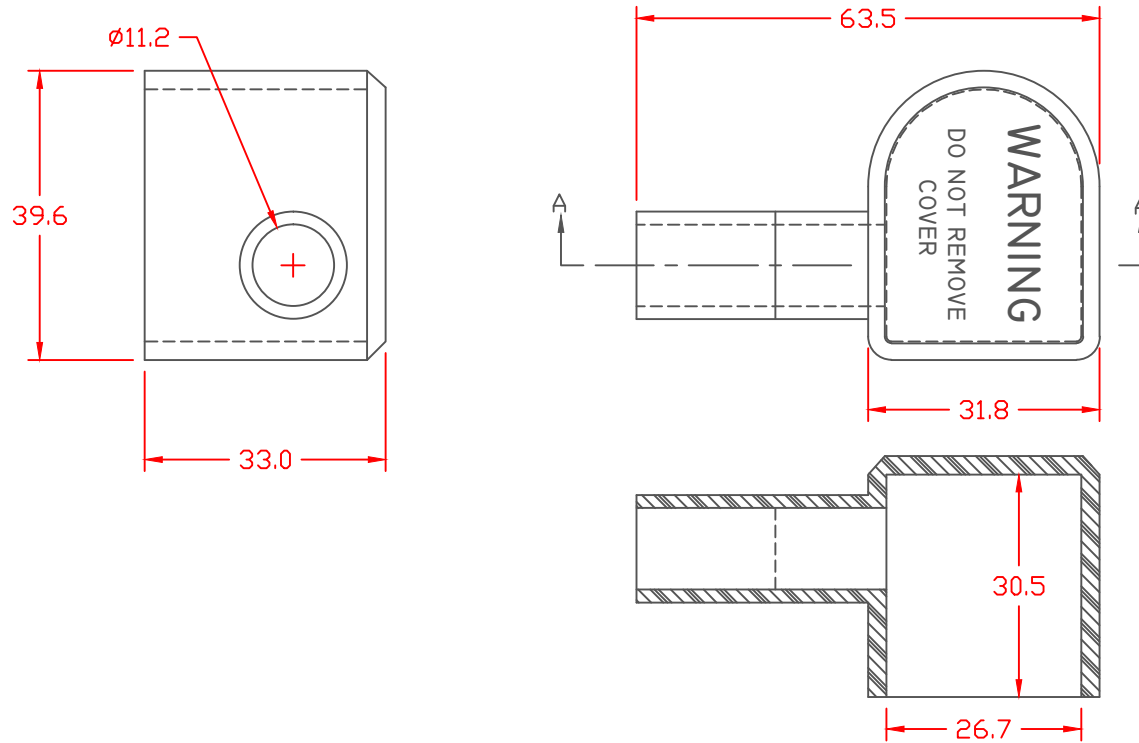

SECTION A-A

TOLERANCE UNLESS OTHERWISE SPECIFIED:  $\pm 0.30^\circ / \pm 0.8\text{mm}$   
 RADIAL DIAMETERS TO BE MEASURED OVER MANDRELS,  
 RING GAGES OR PIN GAGES OF SUITABLE SIZE

VTE Material Part No:  
 Material:  
 Material Part No  
 Max. Operating Temp:  
 Shore Durometer  
 Specific Gravity:  
 Ult. Elongation %:  
 Tensile Strength PSI:  
 U.L. Rating:

1101700102  
 RED PVC  
 M1170 FR RD or Equivalent  
 105 C  
 "A" 15 SEC. 70+/-5  
 1.34  
 275 Minimum  
 1600 PSI Minimum  
 94 V0



	<b>VTE Incorporated</b> 5437 Robinson Road, P.O. Box 790 Pellston, Michigan 49769 Telephone: 1-800-527-9256, 231-539-8000 FAX: 231-539-0914			
	REF:	DATE:	DRN BY: CJC	WEIGHT:
	3-30-98	CHK'D BY:	.04 LBS. / 18.3 G.	

TITLE: U-1 BATTERY TERMINAL BOOT			
MATERIAL:		PART NO.	
COLOR:		444L9F02	
DRG CLASS			