

PROPRIETARY RIGHTS ARE CLAIMED FOR THE MATERIAL DISCLOSED IN THIS DRAWING.

LTR.	REVISIONS	DATE
≠	*****	00-00-98

TYP. WALL THICKNESS = 2.5

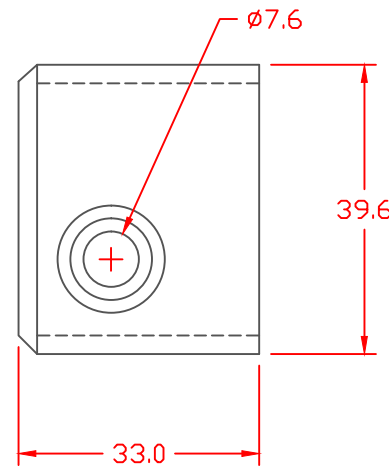
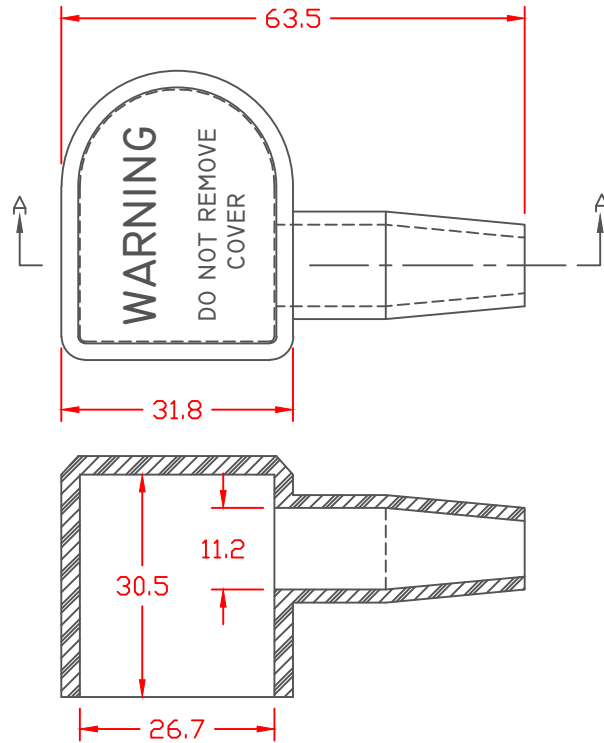

SECTION A-A

TOLERANCE UNLESS OTHERWISE SPECIFIED: ±.030"/±0.8mm  
 RADIAL DIAMETERS TO BE MEASURED OVER MANDRELS,  
 RING GAGES OR PIN GAGES OF SUITABLE SIZE

VTE Material Part No:	1101700114
Material:	BLACK PVC
Material Part No:	M1170-FR or Equivalent
Max. Operating Temp:	105 C
Shore Durometer:	"A" 15 SEC. 70+/-5
Specific Gravity:	1.34
Ult. Elongation %:	275 Minimum
Tensile Strength PSI:	1600 PSI Minimum
U.L. Rating:	94 V0

**VTE Incorporated**  
 5437 Robinson Road, P.O. Box 790  
 Pellston, Michigan 49769  
 Telephone: 1-800-527-9256, 231-539-8000  
 FAX: 231-539-0914

REF:	DATE:	DRN BY:	WEIGHT:
	3-30-98	CJC	.04 LBS. / 18.3 G.
TITLE:		CHK'D BY:	
U-1 BATTERY TERMINAL BOOT			
MATERIAL:		PART NO.	
		444R6F14	
COLOR:	DRG CLASS		

