

PROPRIETARY RIGHTS ARE CLAIMED FOR THE MATERIAL DISCLOSED IN THIS DRAWING.

LTR.	REVISIONS	DATE
≠	*****	00-00-98

TYP. WALL THICKNESS = 2.5

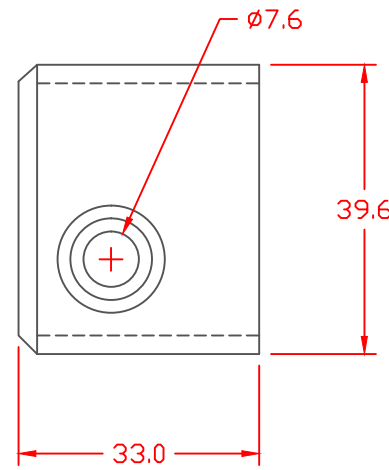
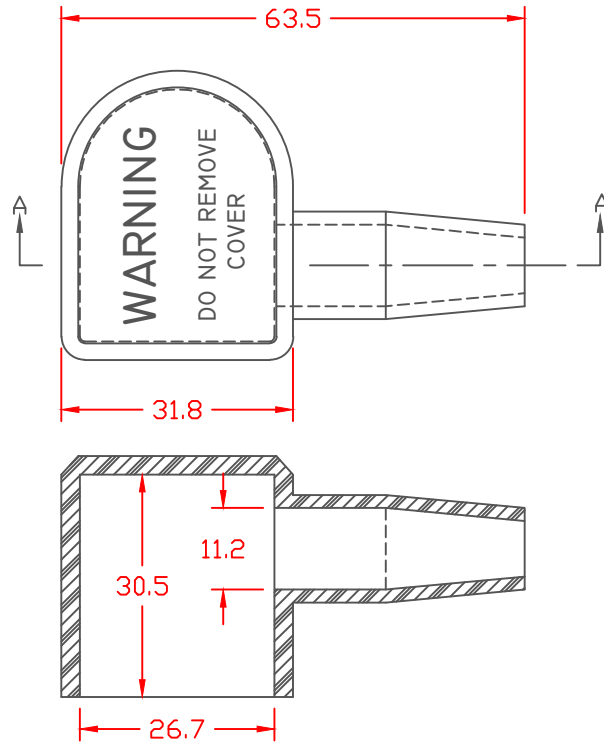

SECTION A-A

VTE Material Part No:	1101650109
Material:	BLUE PVC
Material Part No:	05-916R
Max. Operating Temp:	105 C
Shore Durometer:	"A" 65
Specific Gravity:	1.27
Ult. Elongation %:	325
Brittle Temp:	****
Tensile Strength PSI:	1500 PSI
Dielectric Strength, v./ml:	****
U.L. Rating:	****
MEETS:	****

TOLERANCE UNLESS OTHERWISE SPECIFIED: ±.030"/±0.8mm
 RADIAL DIAMETERS TO BE MEASURED OVER MANDRELS,
 RING GAGES OR PIN GAGES OF SUITABLE SIZE

	VTE Incorporated 5437 Robinson Road, P.O. Box 790 Pellston, Michigan 49769 Telephone: 1-800-527-9256, 231-539-8000 FAX: 231-539-0914			
	REF:	DATE:	DRN BY: CJC	WEIGHT:
	3-30-98	CHK'D BY:	.04 LBS. / 18.3 G.	

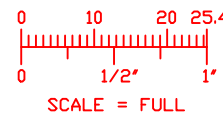

TITLE: U-1 BATTERY TERMINAL BOOT			
MATERIAL:		PART NO. 444R6V09	
COLOR:	DRG CLASS		