

PROPRIETARY RIGHTS ARE CLAIMED FOR THE MATERIAL DISCLOSED IN THIS DRAWING.

TYP. WALL THICKNESS = 2.0 TYP. RADIUS = 2.0

LTR.	REVISIONS	DATE
≠	*****	00-00-98

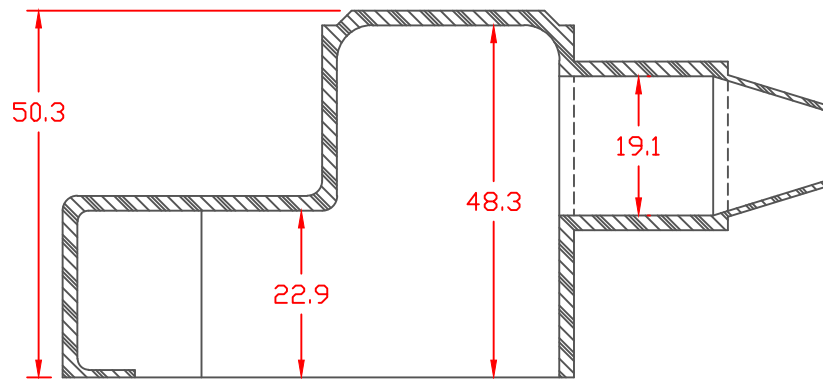

SECTION A-A

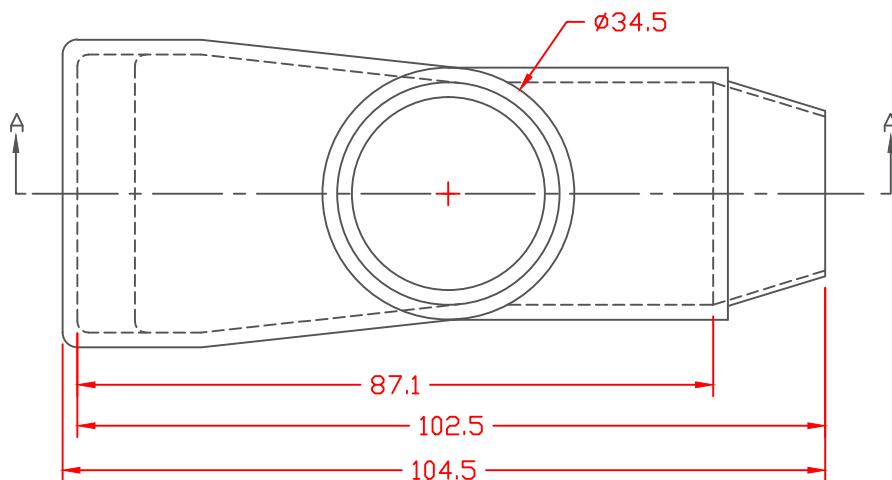
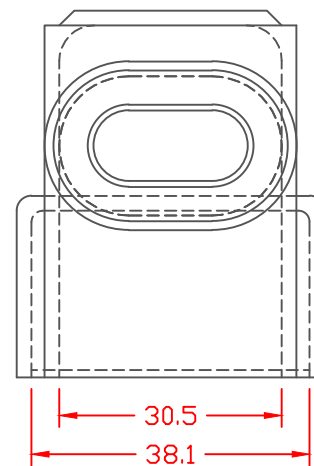

Material:
Material Part No

Thermoplastic Elastomer
(Santoprene 201-64 or Equivalent)
Durometer 67 to 73 Shore A

SEAL
SEAL THICKNESS = .8

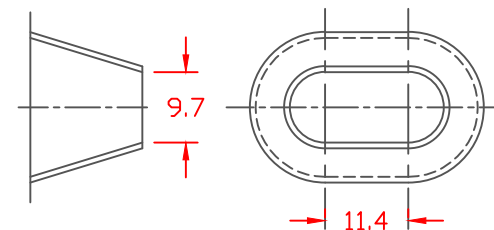

Fits Multiple Cables

TOLERANCE UNLESS OTHERWISE SPECIFIED: $\pm 0.30^\circ / \pm 0.8\text{mm}$
RADIAL DIAMETERS TO BE MEASURED OVER MANDRELS,
RING GAGES OR PIN GAGES OF SUITABLE SIZE



VTE Incorporated

5437 Robinson Road, P.O. Box 790
Pellston, Michigan 49769
Telephone: 1-800-527-9256, 231-539-8000
FAX: 231-539-0914

REF:	DATE: 3-31-98	DRN BY: JC CHK'D BY:	WEIGHT: 075 LBS. / 33.9 G
------	------------------	-------------------------	------------------------------

TITLE: MARINE ADAPTER WING NUT BOOT

MATERIAL:	PART NO. 456N9T02
COLOR:	DRG CLASS

